

---

# **Assembly tutorial**

**——Mechanical Fighting Scorpion**

---

**1.The way to assemble legs**

**2.Assembly of sea turtle**

**3.The way to assemble tummy**

**4.The way to assemble back cannon**

**5.Whole assembly**

**Note:** When assembling, some parts need to be pulled apart with the nip-nosed pliers

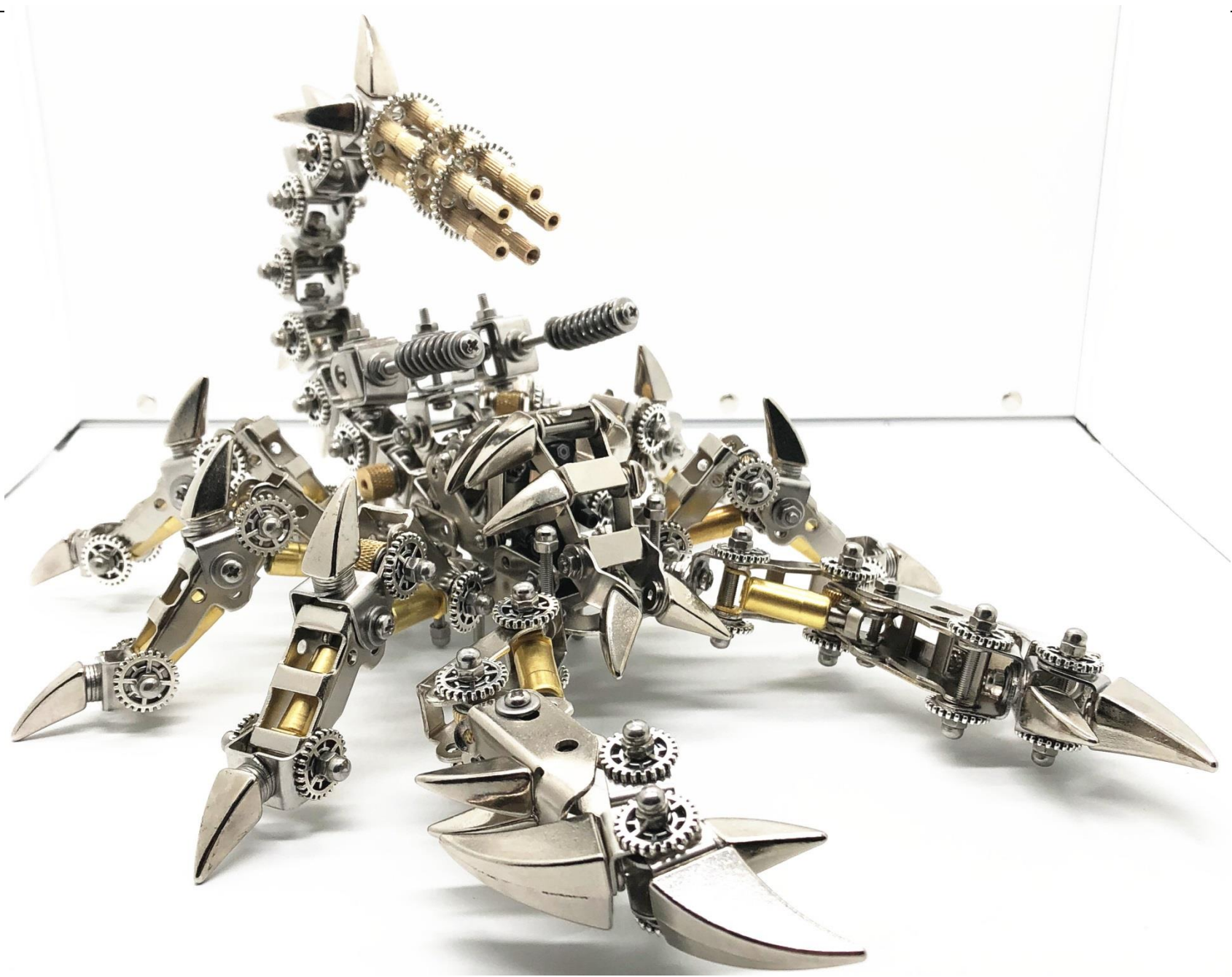

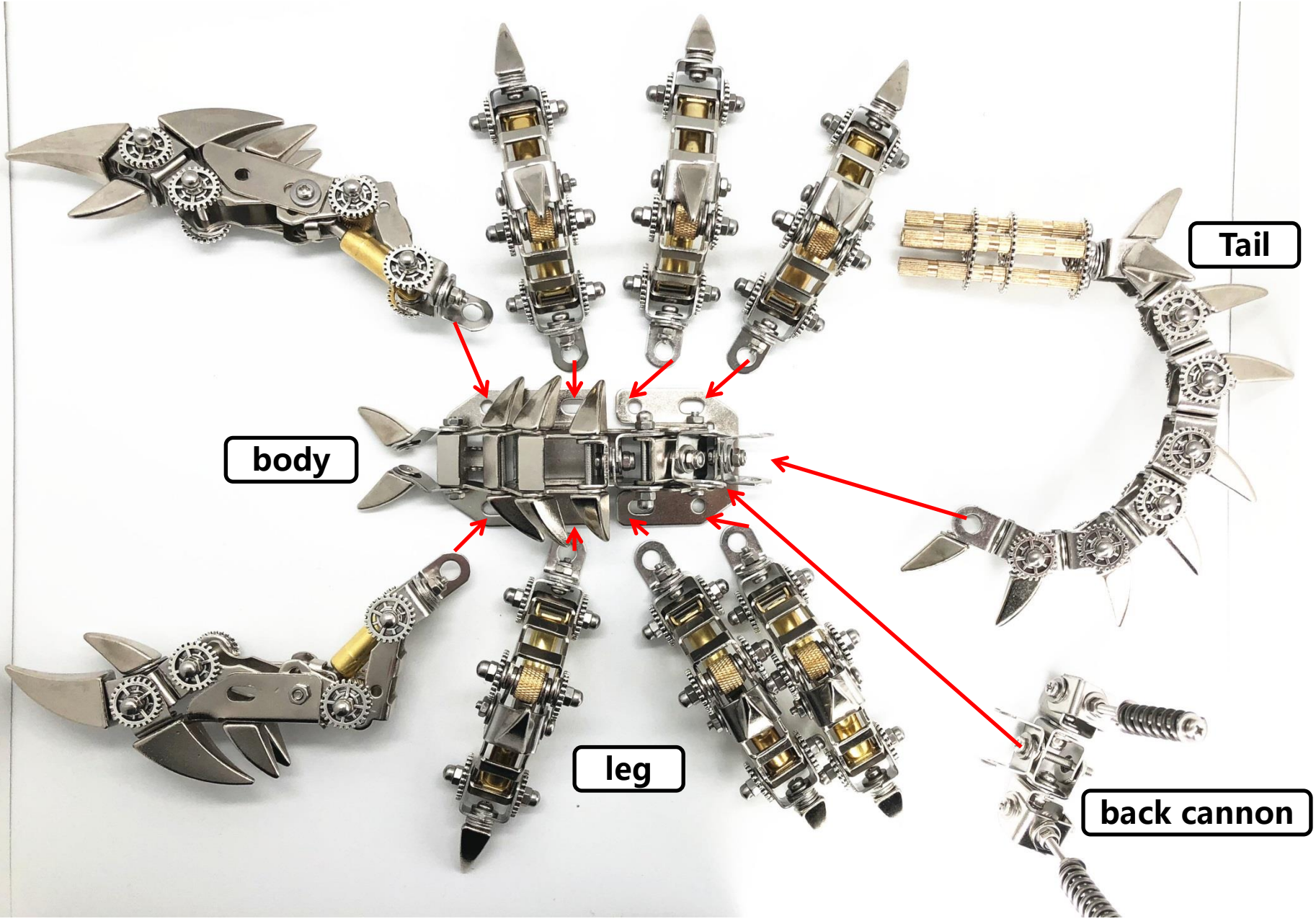

**body**

**leg**

**Tail**

**back cannon**

# 1. assembly of legs tip



### assembly of legs tip

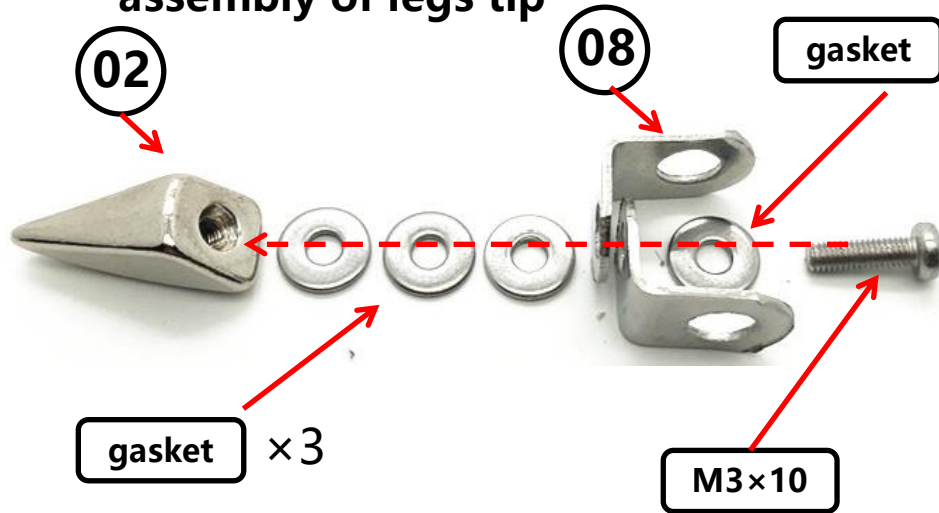

1

2

### Assembly of connecting parts of legs and body



Note: Use a hole of number 8 part on the short side

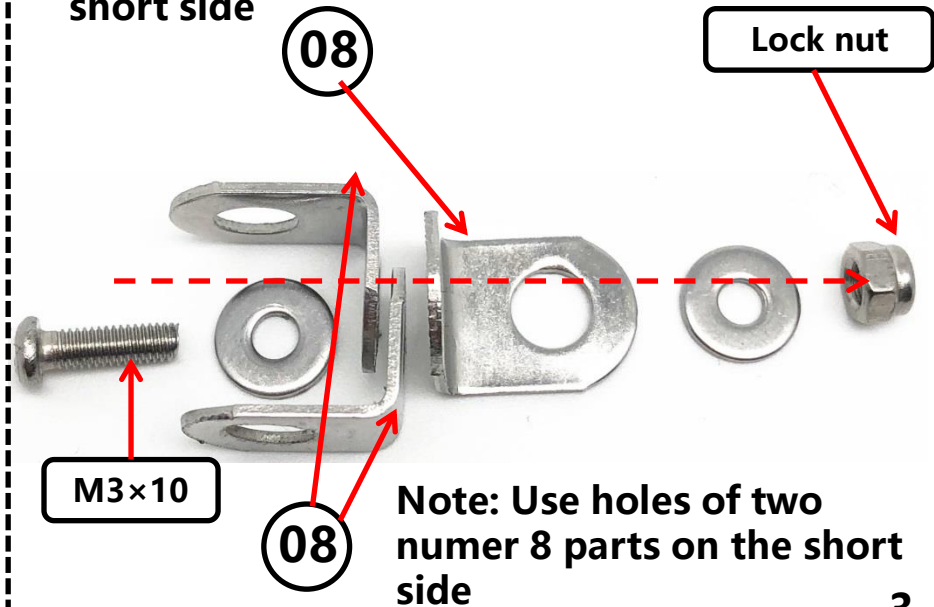

Note: Use holes of two number 8 parts on the short side

4

3

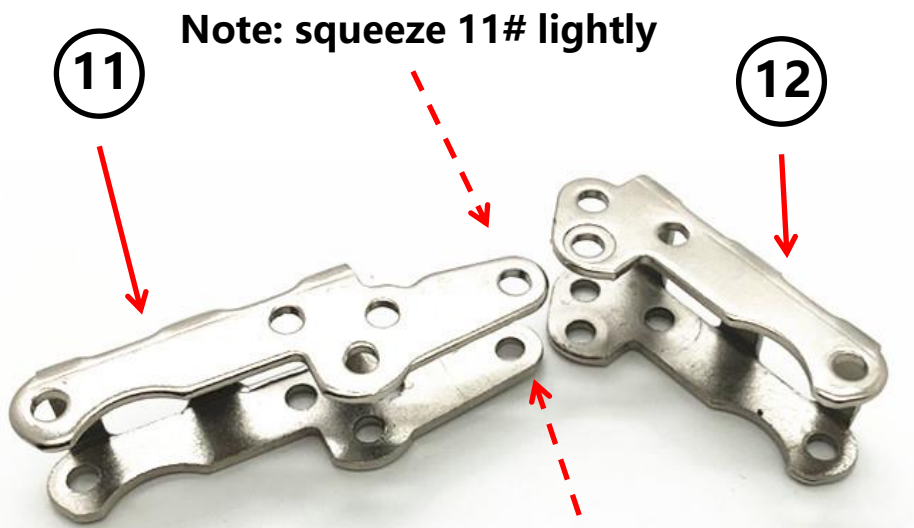

5

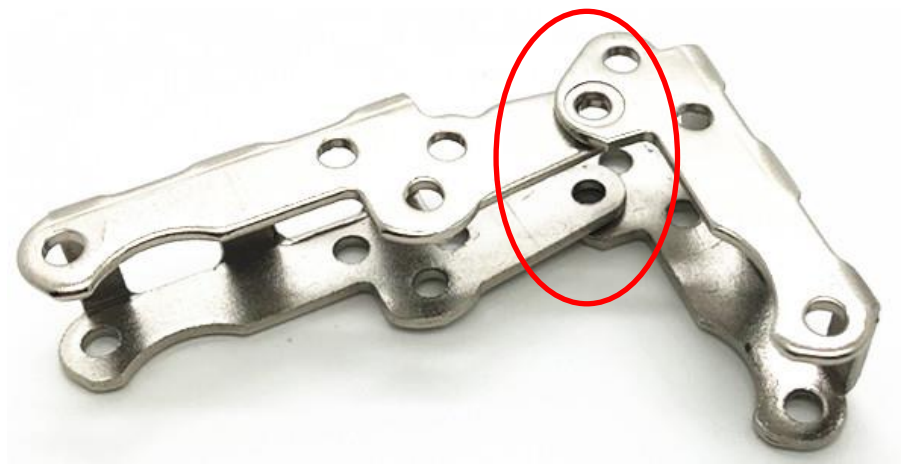

6

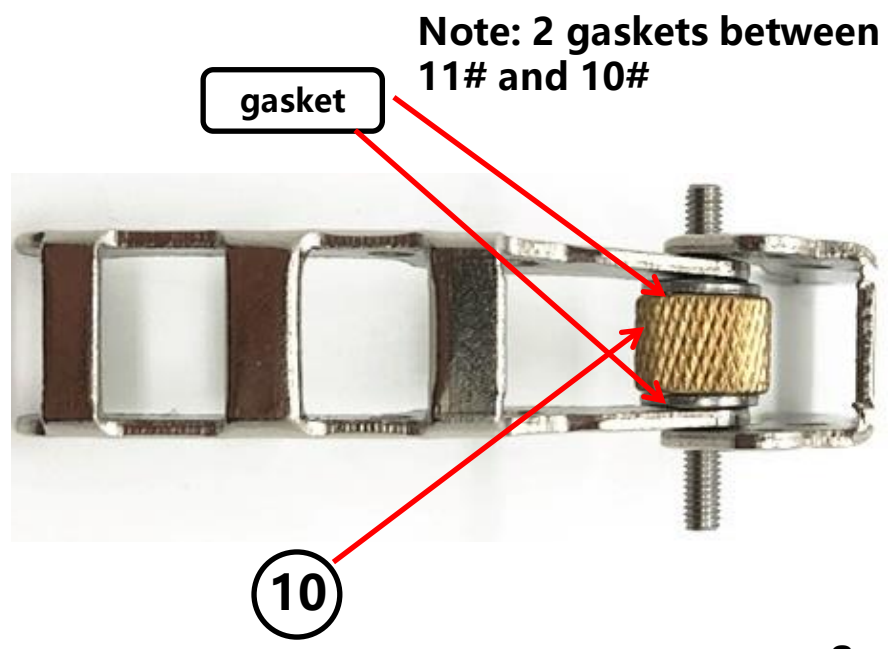

8

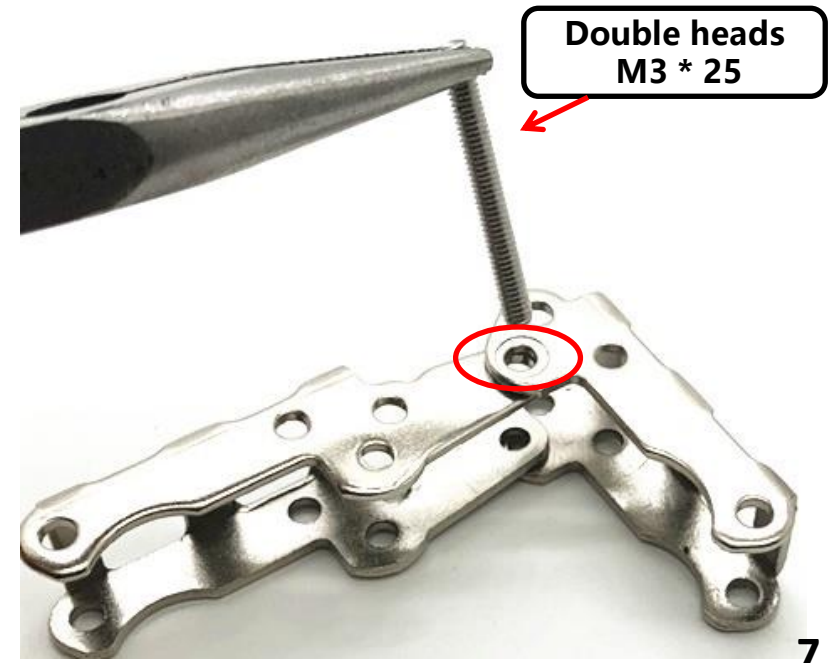

7

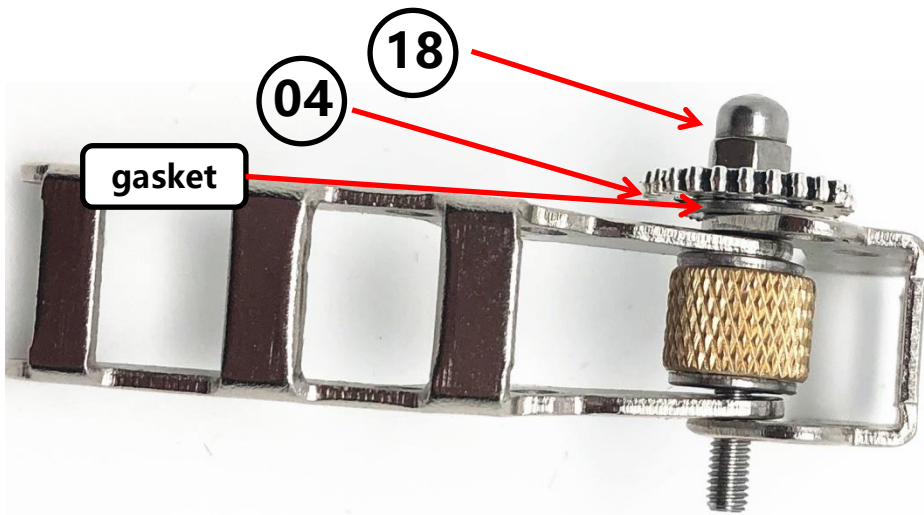

9



10

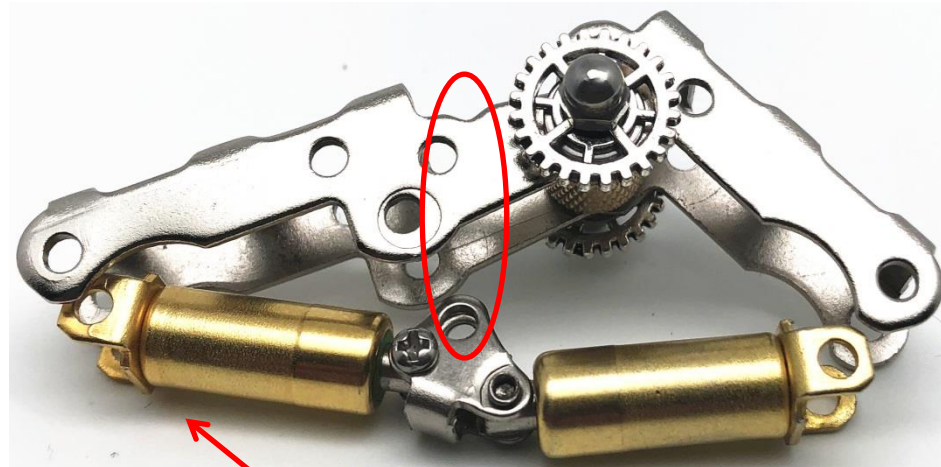

**07** Note: two parts in one 7# 12



11



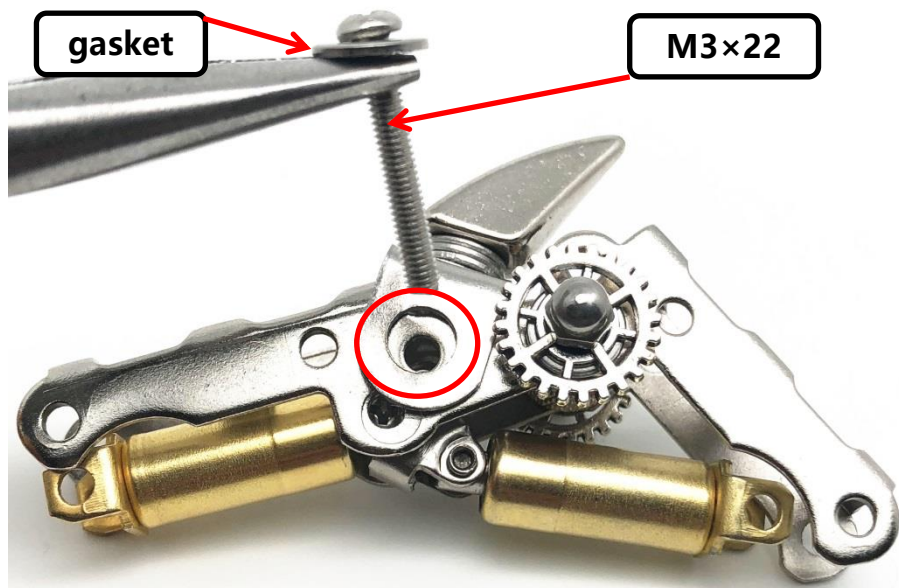

13

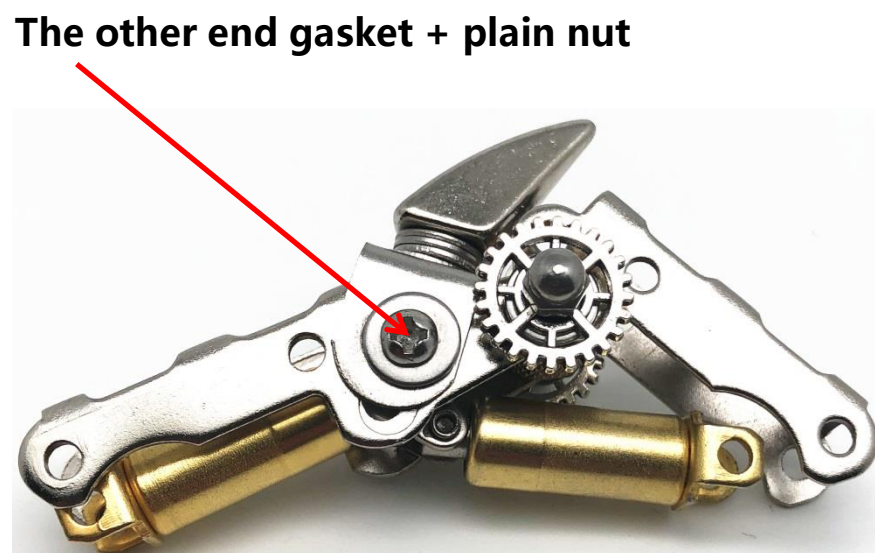

14

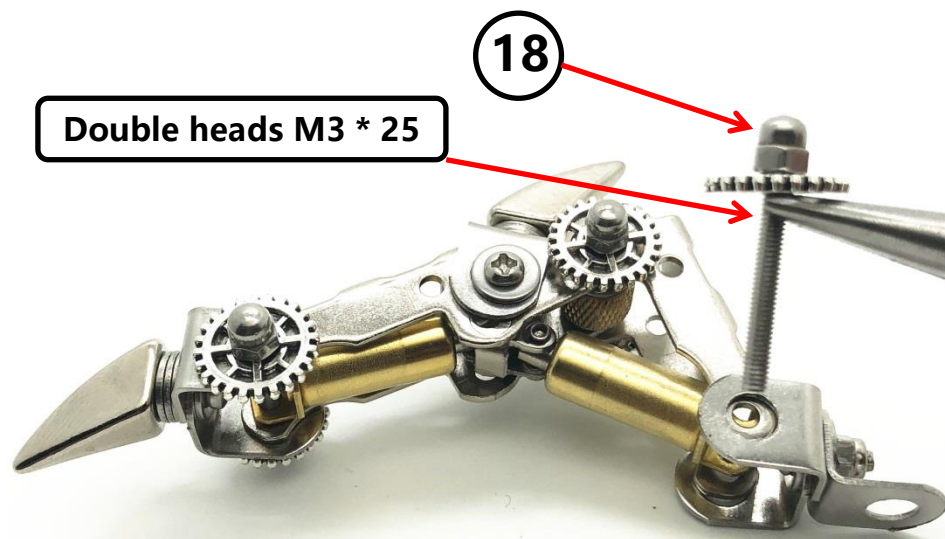

16

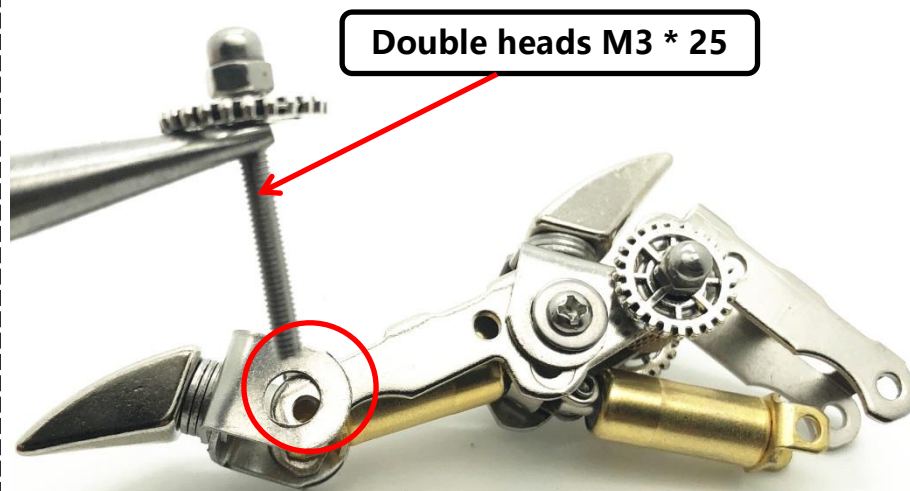

15



17

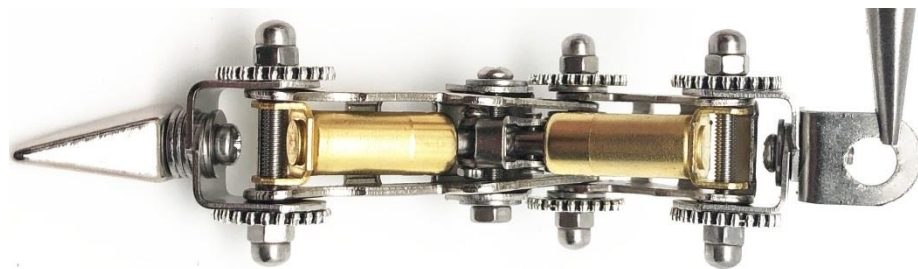

18



×8

20

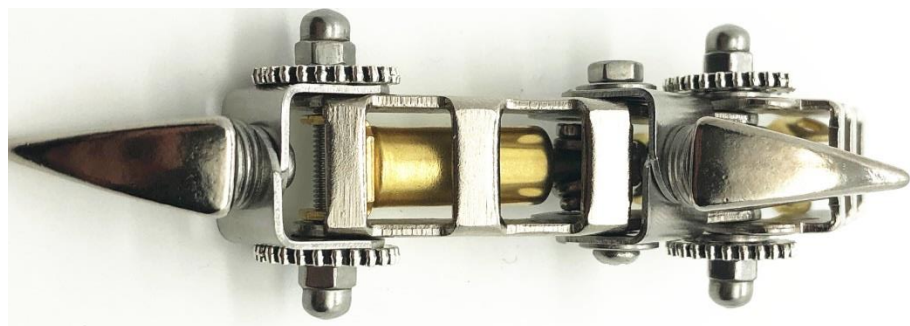

19

**Congratulations! The assembly of legs is done**

**Assembly of sea turtle**





Note: Use holes of one number 8 parts on the short side

08

Lock nut

M3×10

08

Note: Use holes of two number 8 parts on the short side

21

### 螯与身体连接件组装



22

Rotate to the following Angle

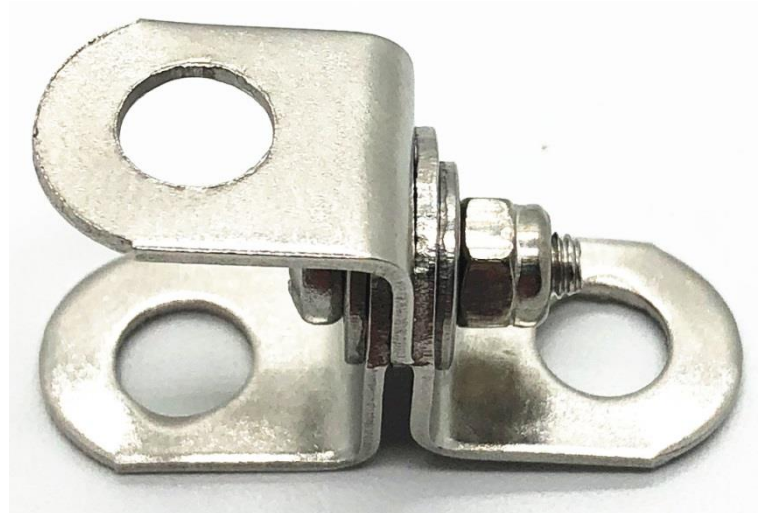

23



24

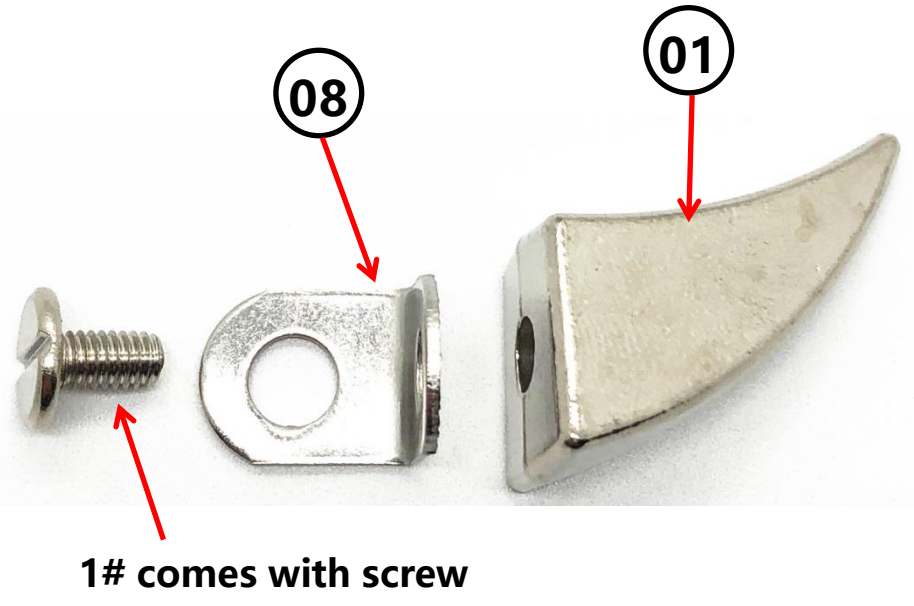
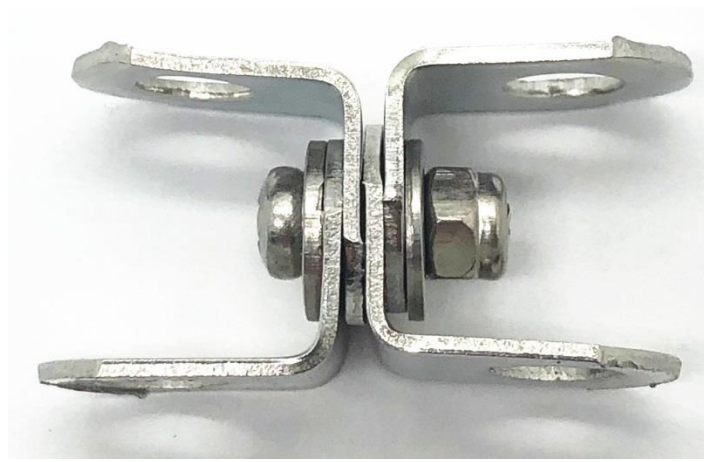
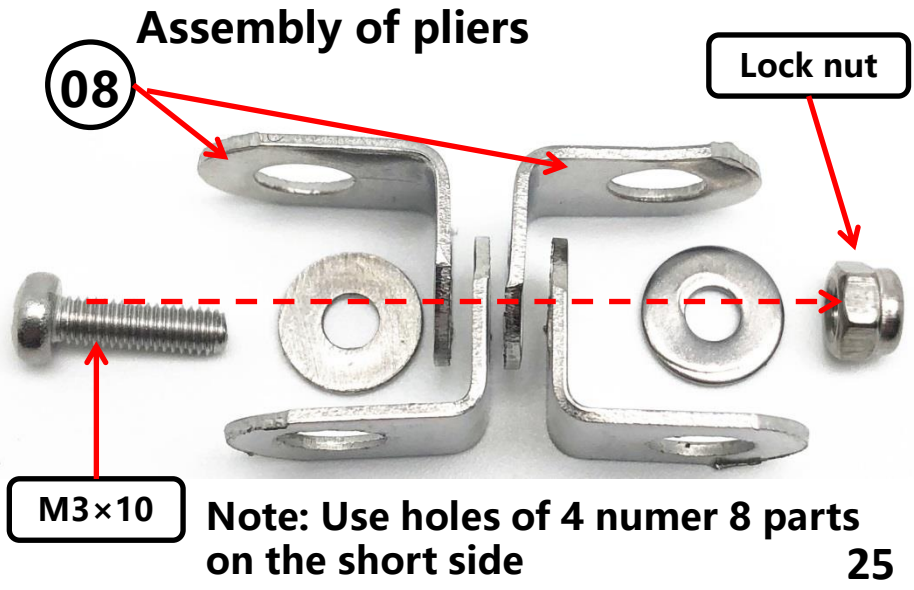

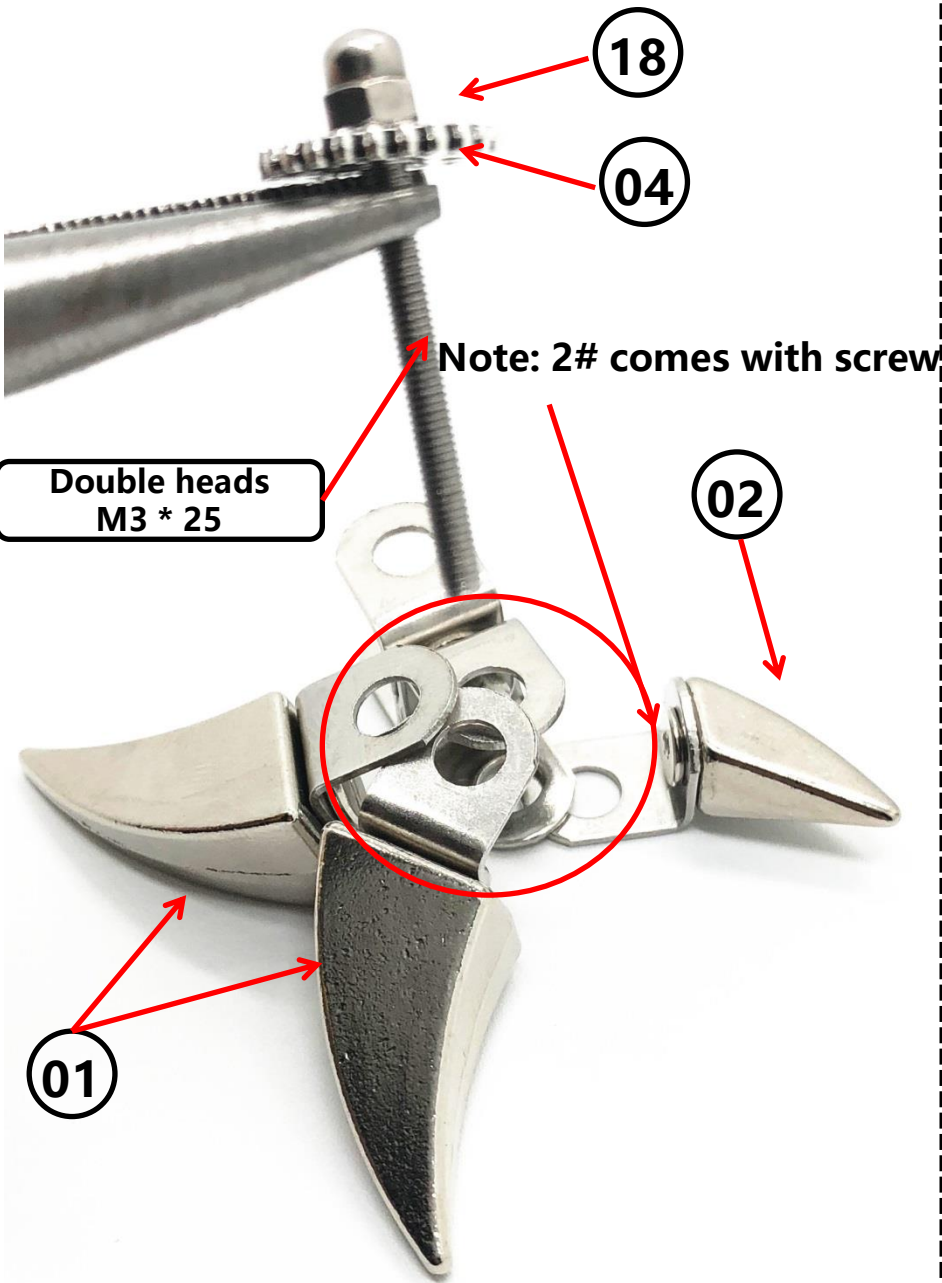

# Armor for sea turtle

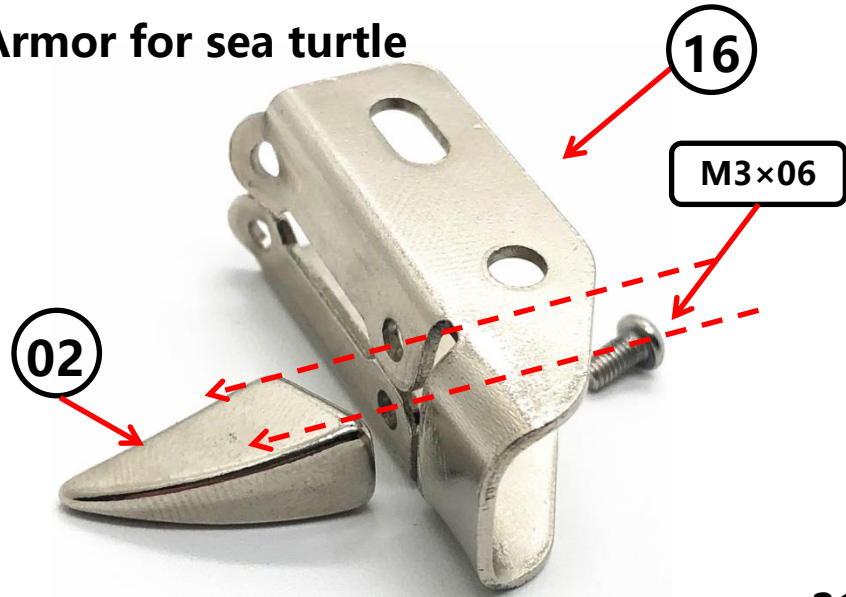

31



Note: when installing # 2, do not tighten the first one, and tighten them together after installing the second one

32



33

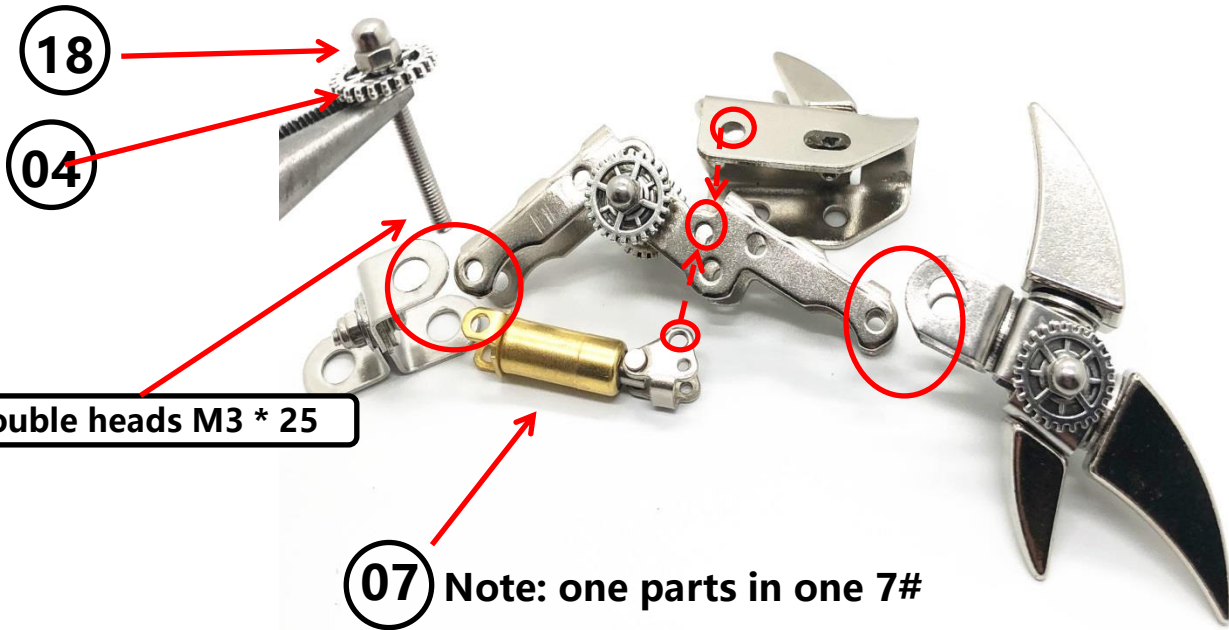



36



37

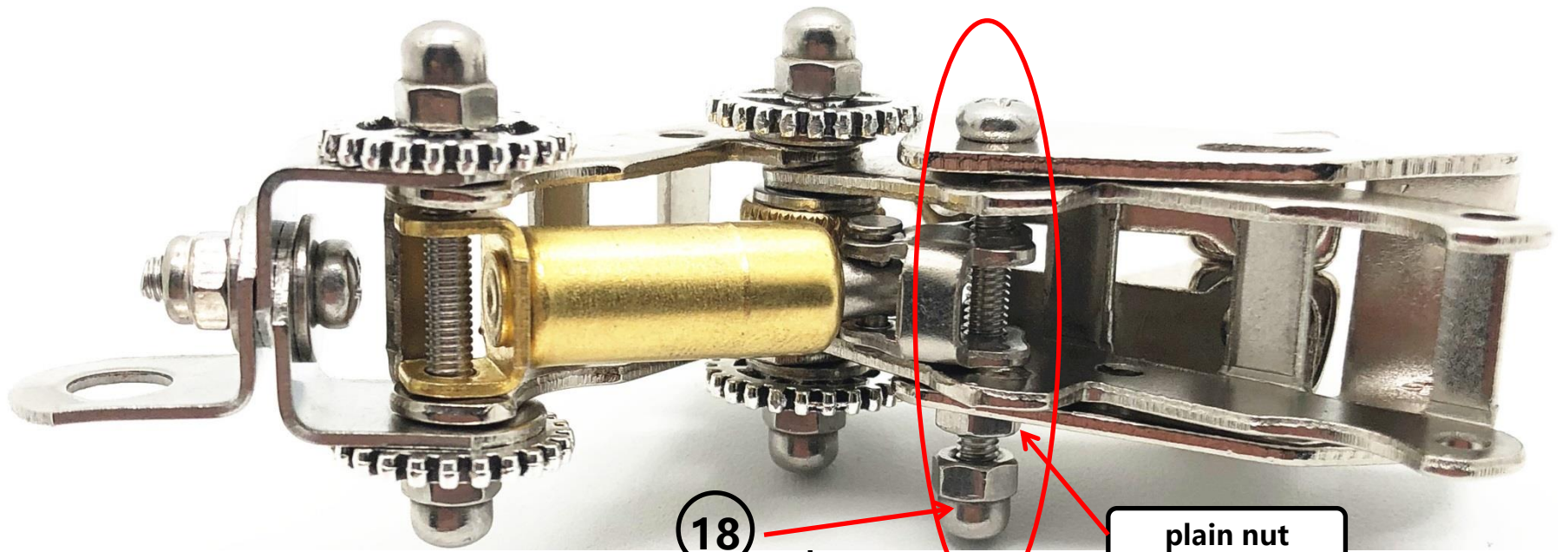

18

plain nut

38

18

04

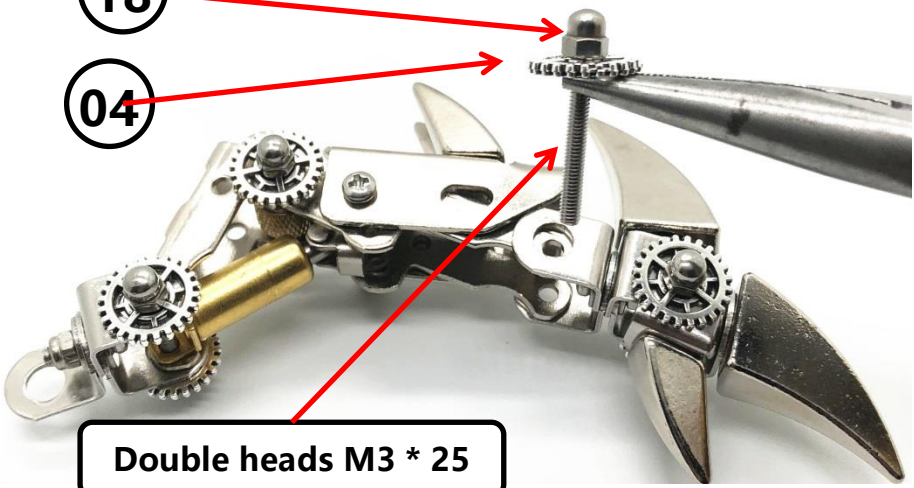

Double heads M3 \* 25

39



40

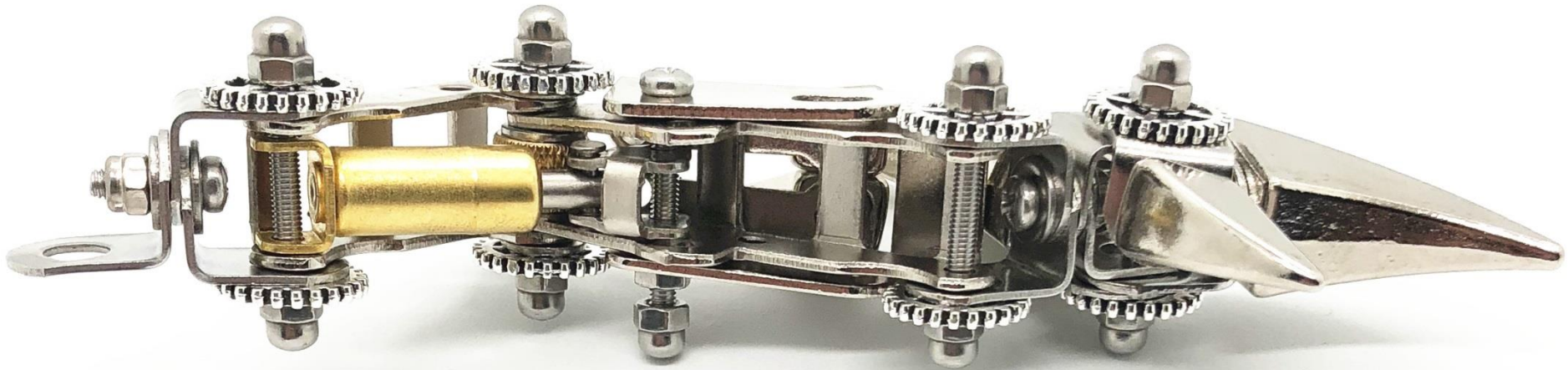

41

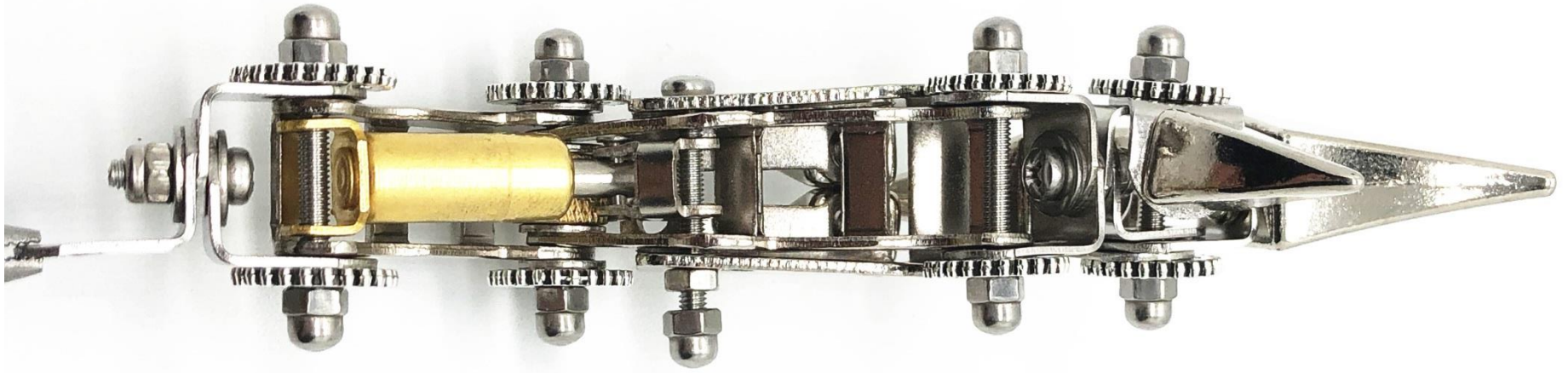

42



43

**Congratulations! The assembly of sea turtle is done**

**The way to assemble body**

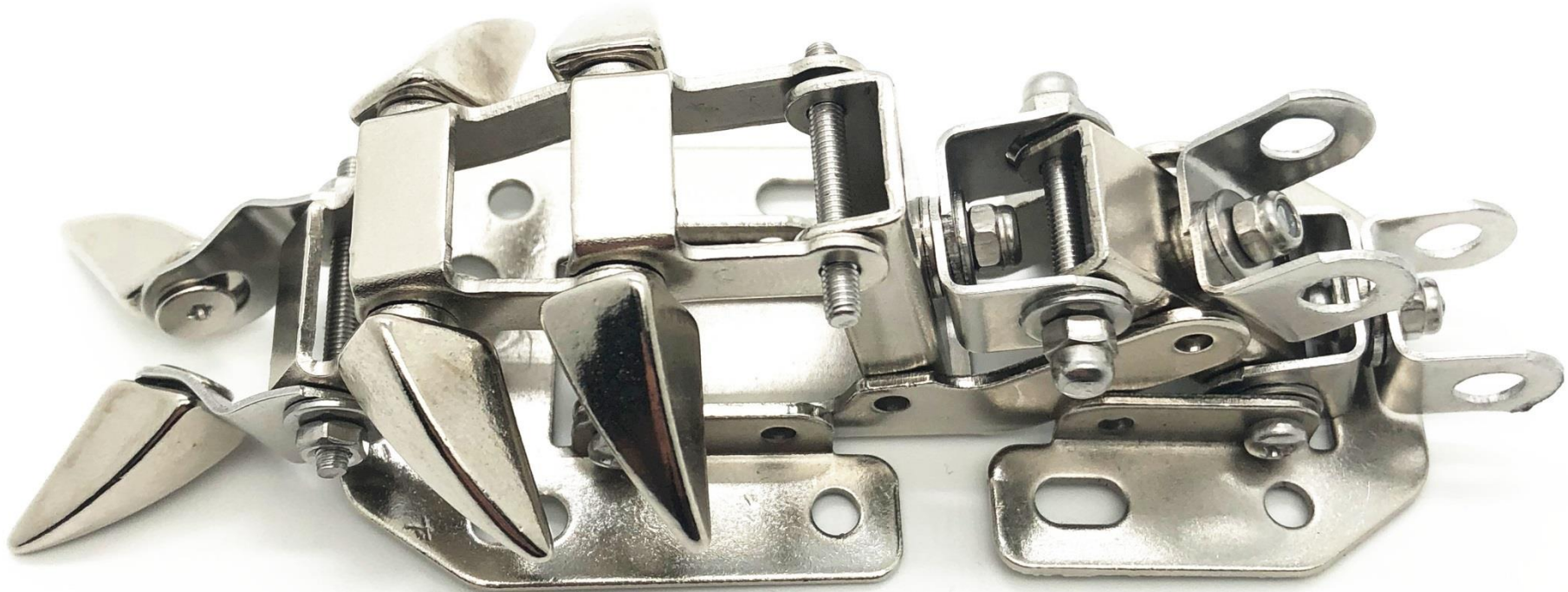

Parts connecting the tummy to the body

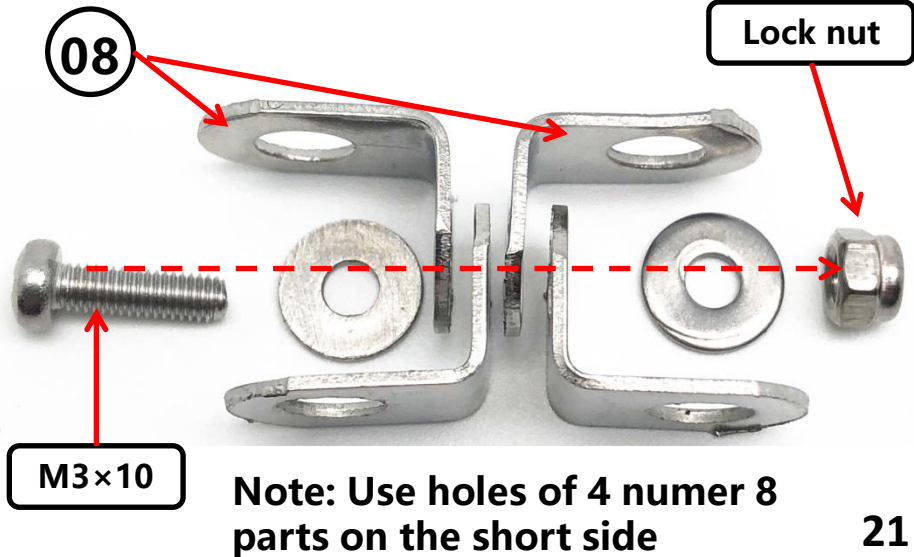

22

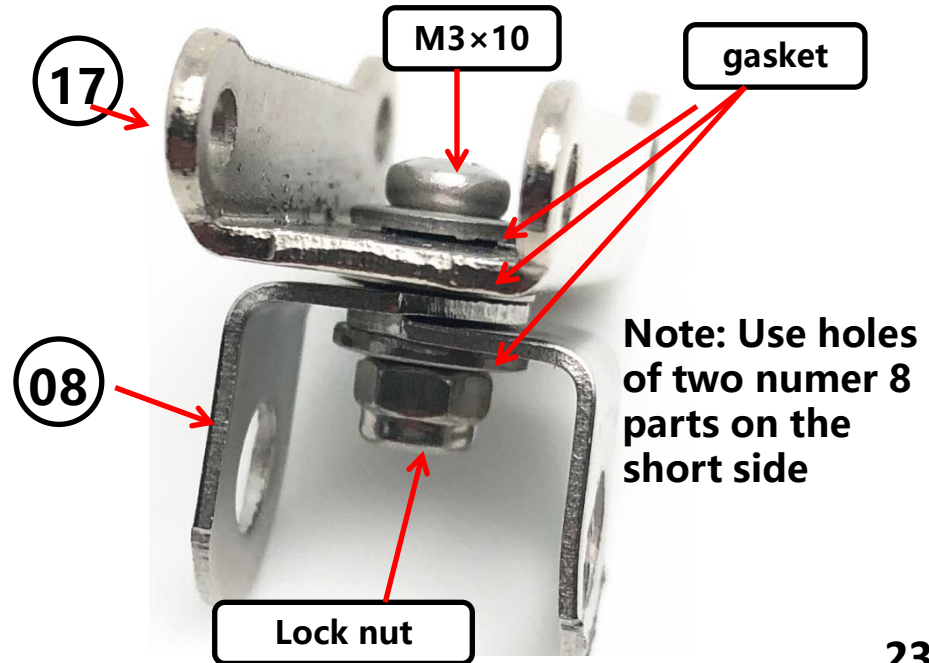
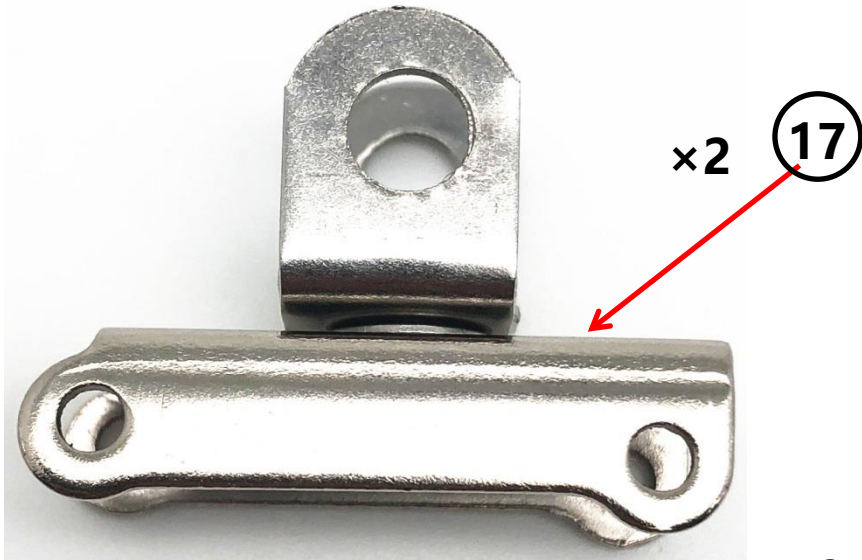

**Note: The ends of # 17 are different**



25

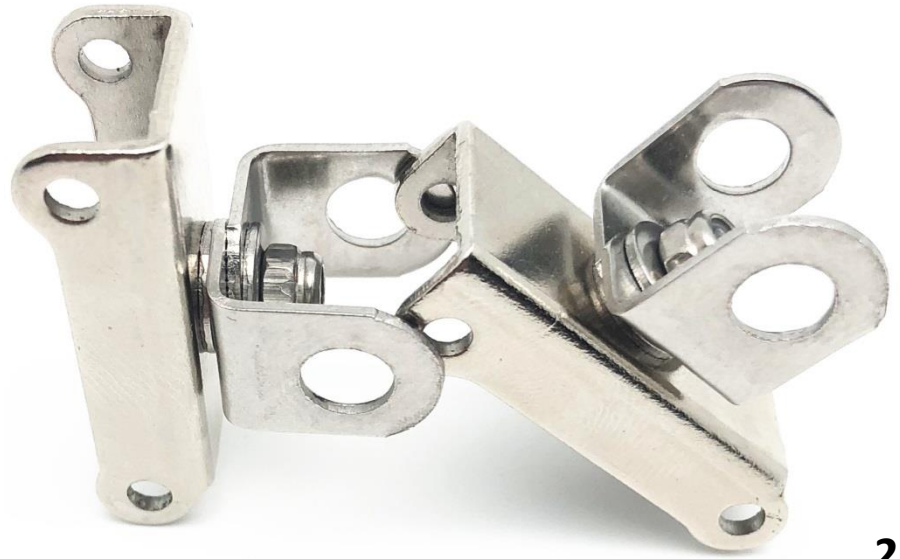

26

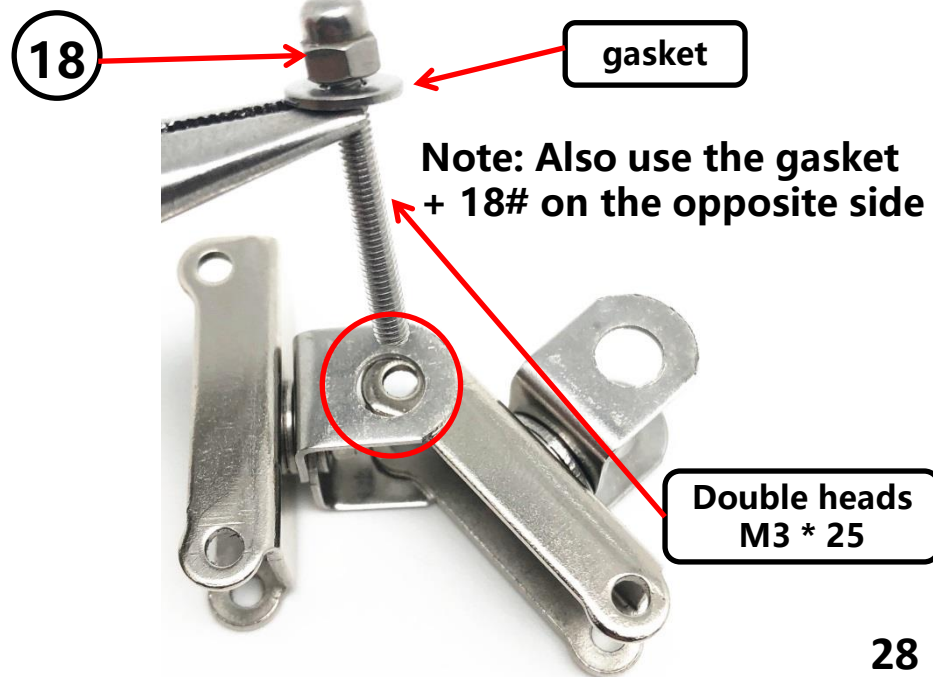

28

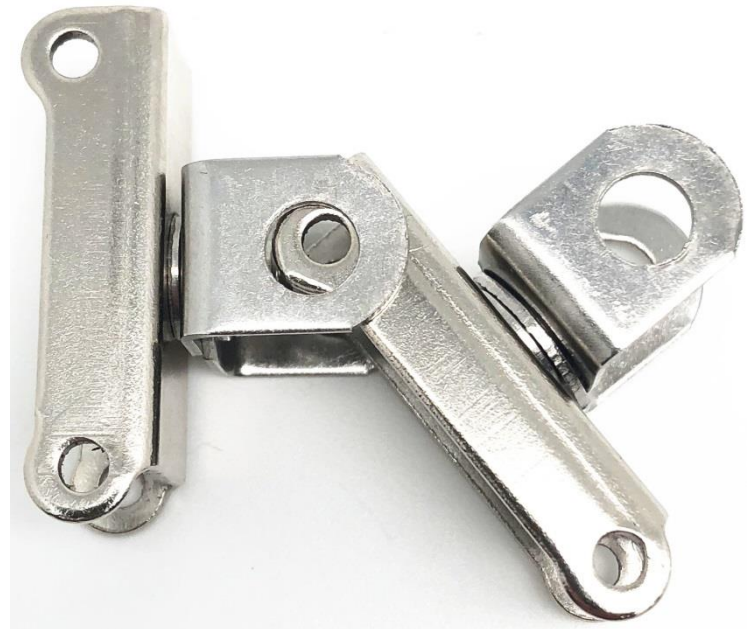

27

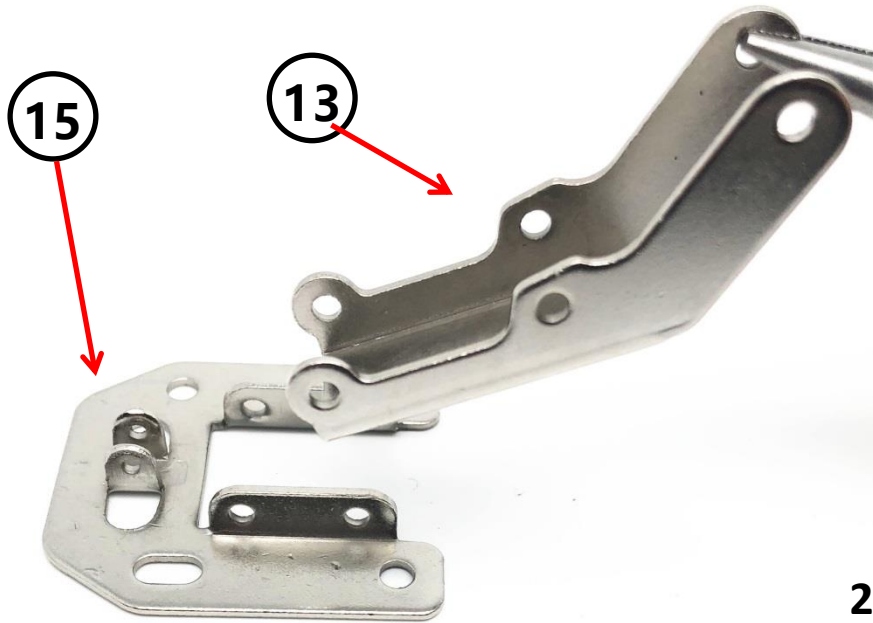

29



30

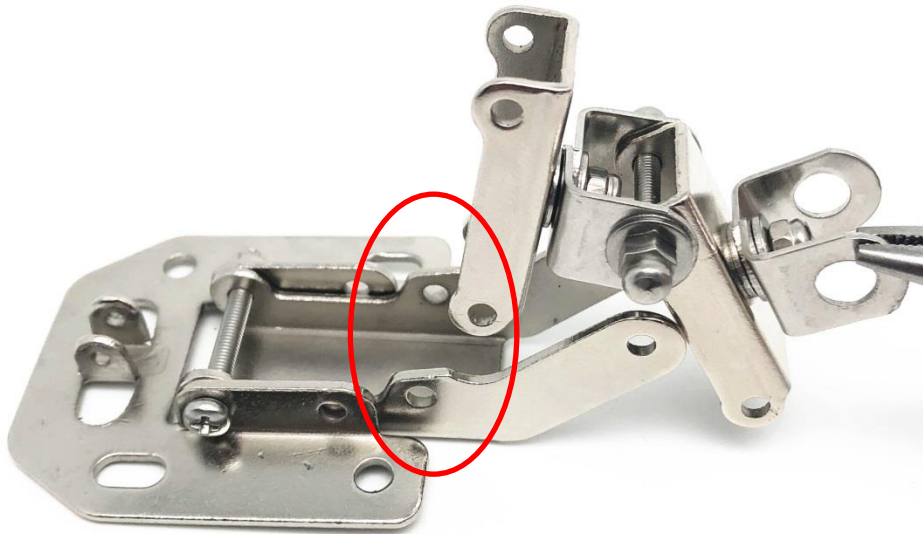

32

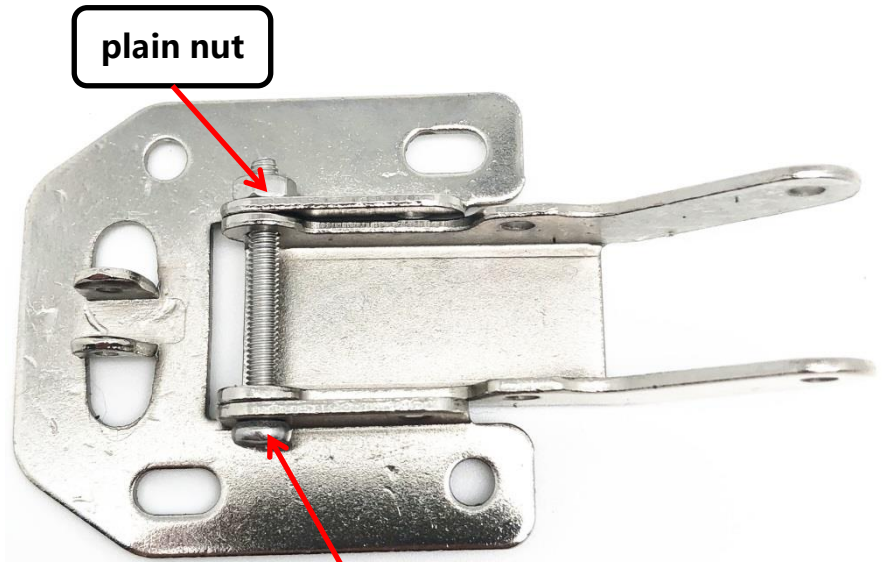

plain nut

Double heads M3 \* 25

31



33

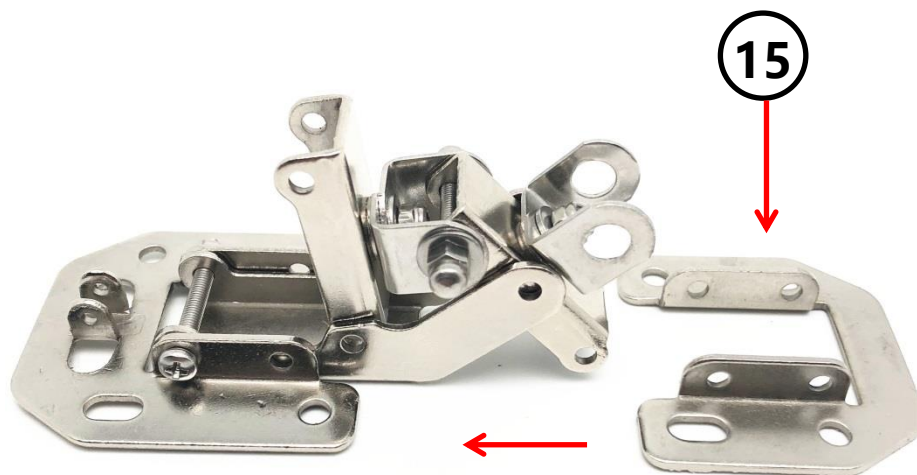

34

**Note: the tummy and body connector is inserted between # 17 and # 15**

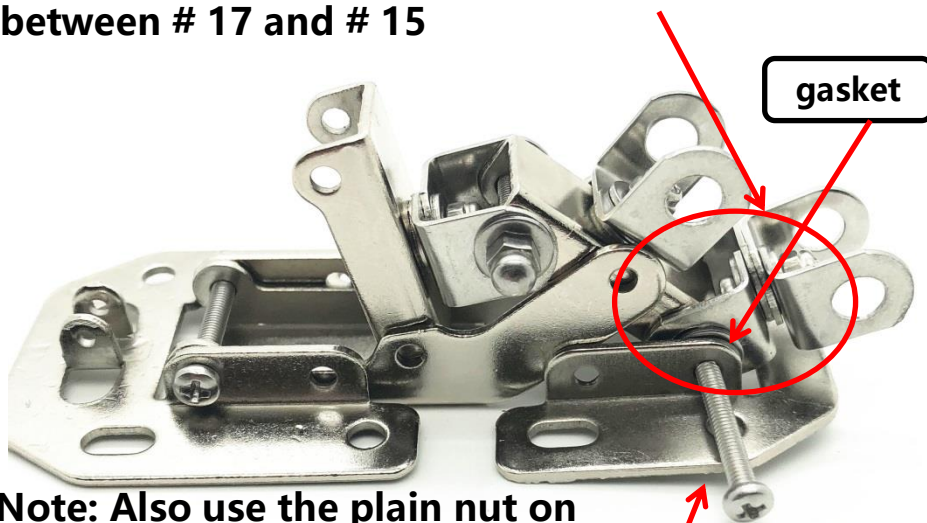

**Note: Also use the plain nut on the opposite side**

**Double heads M3 \* 25**

36

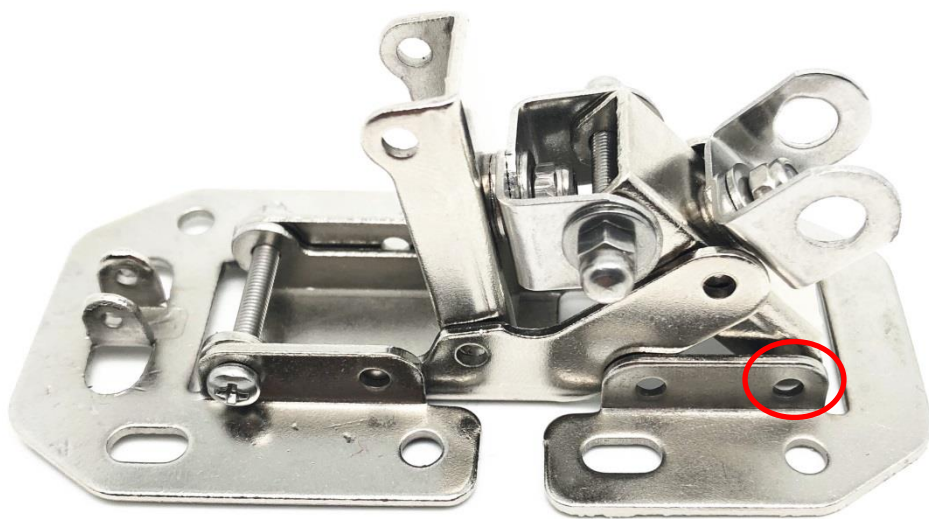

35

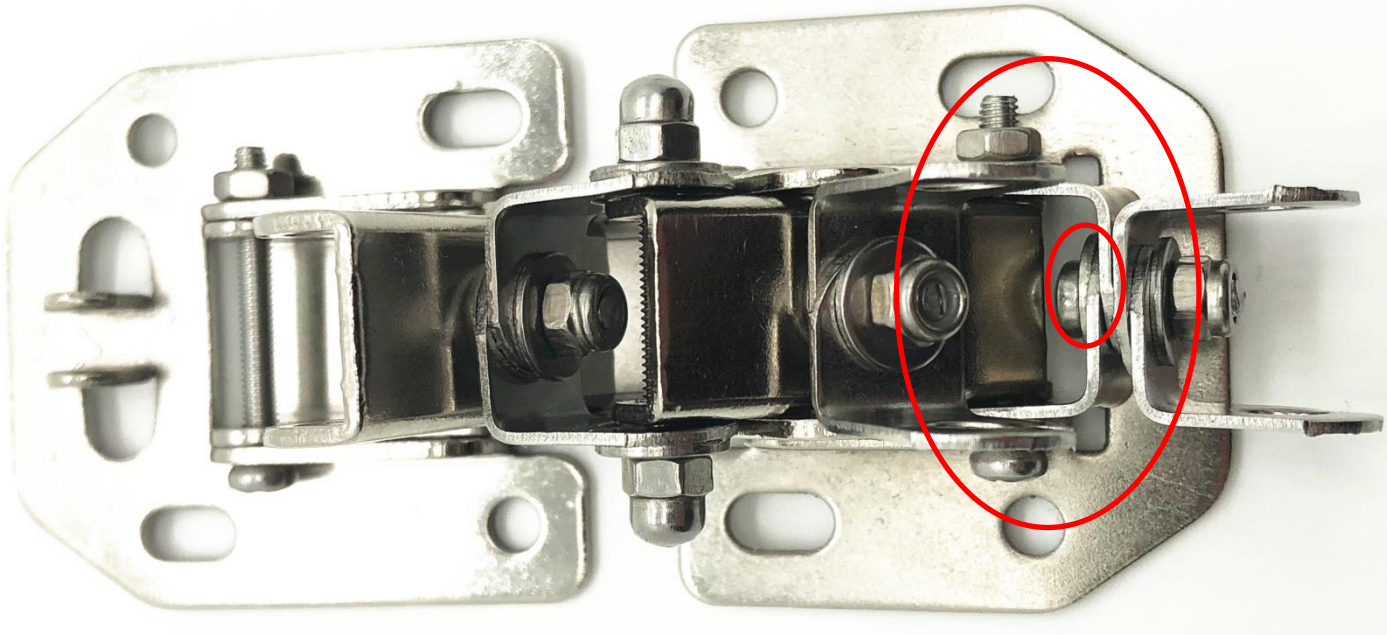

**Note: Also use the plain nut on the opposite side**

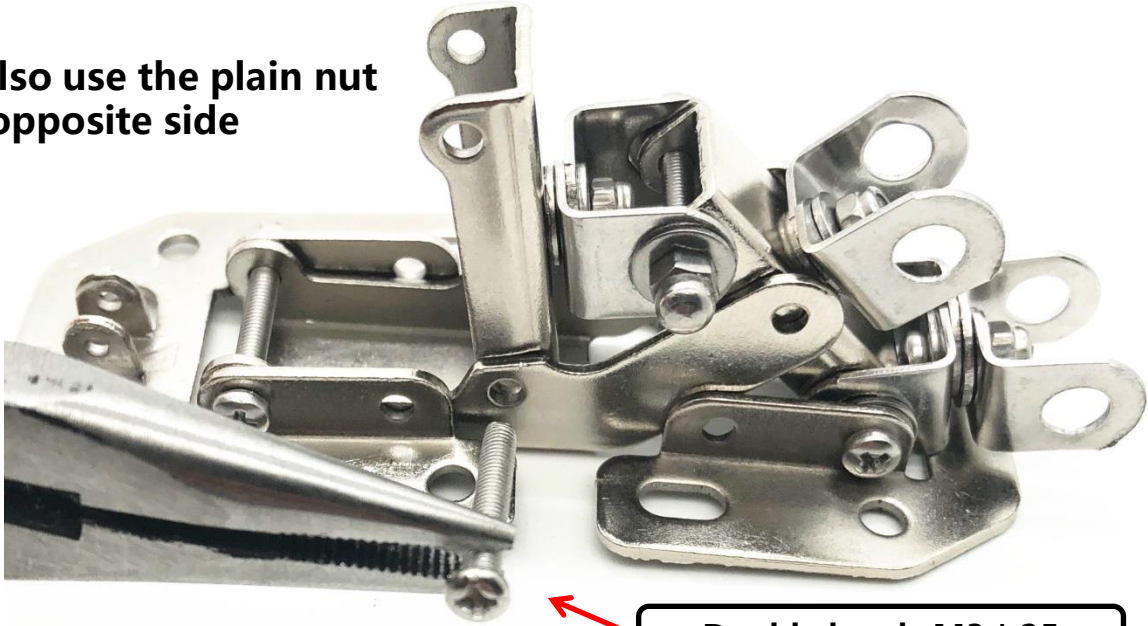

**Double heads M3 \* 25**

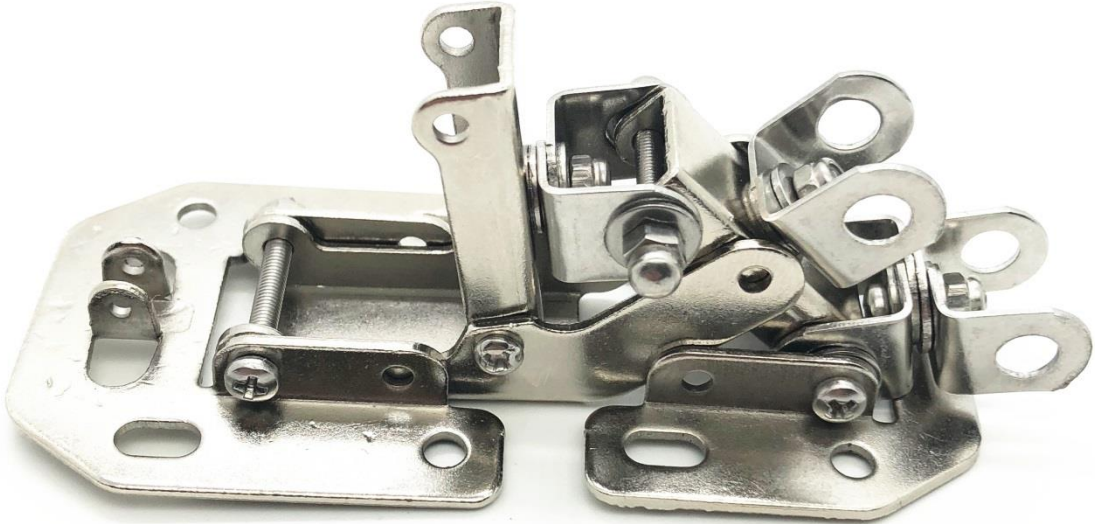

14

cockpit canopy



38

02

plain nut

M3x6

08

Special No 8

Double heads  
M3 \* 25

plain nut

gasket

40

39

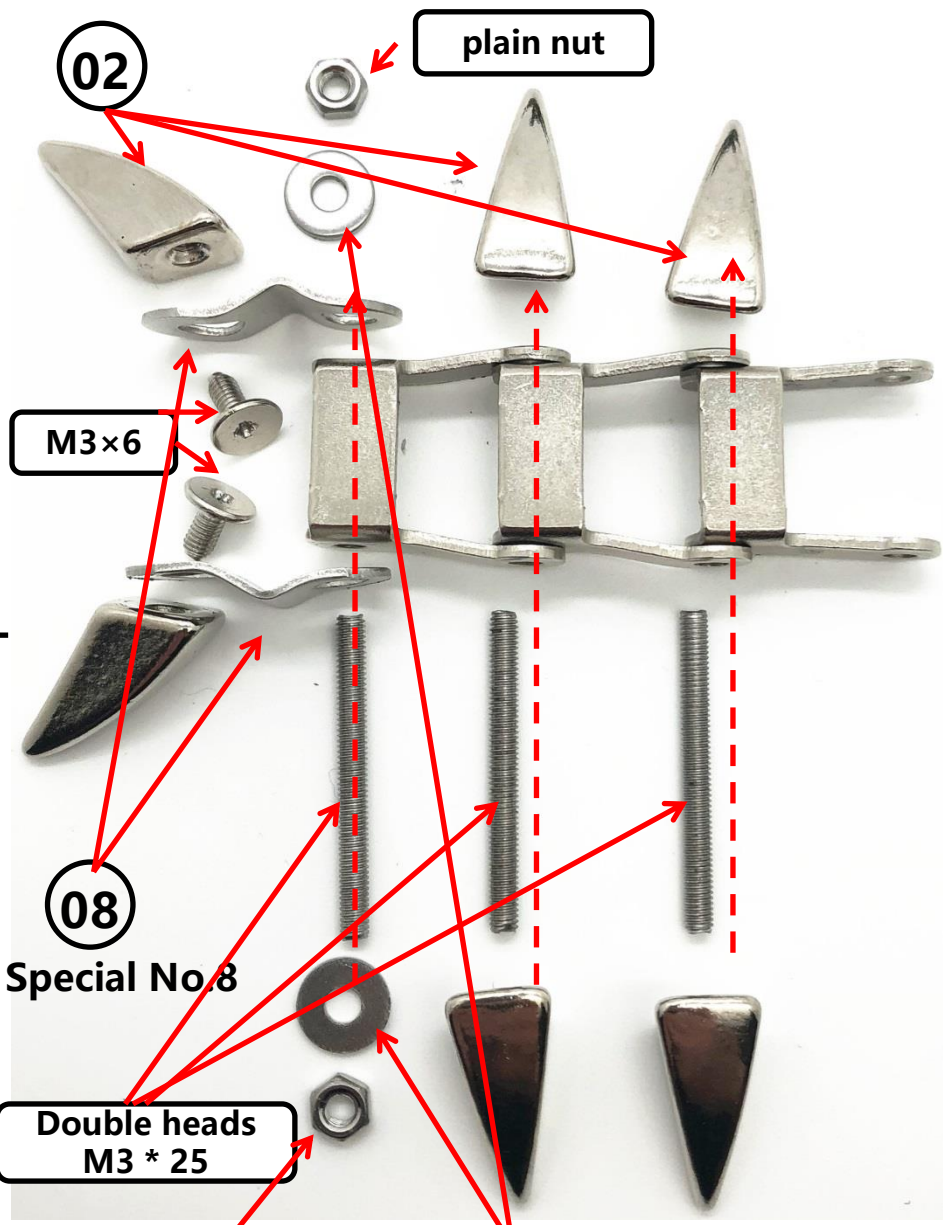



66

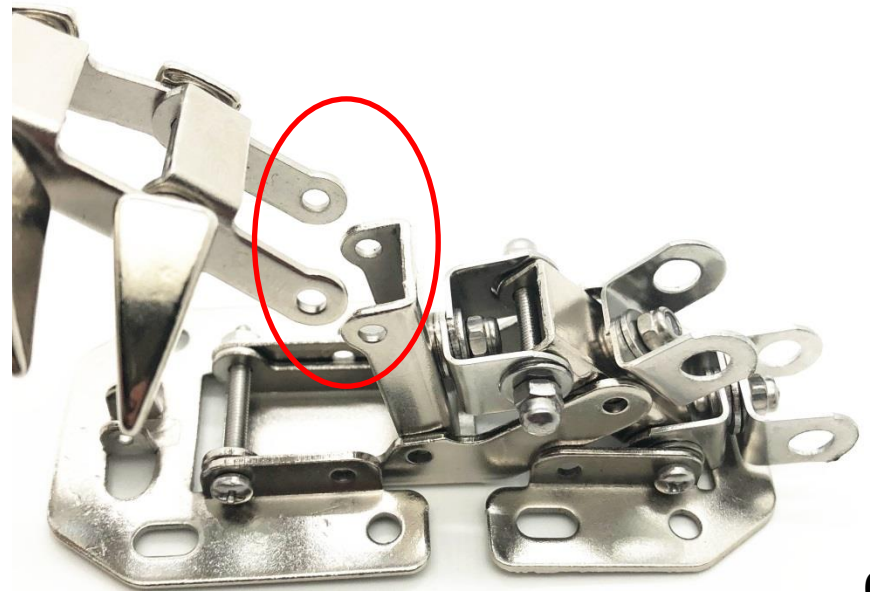

67

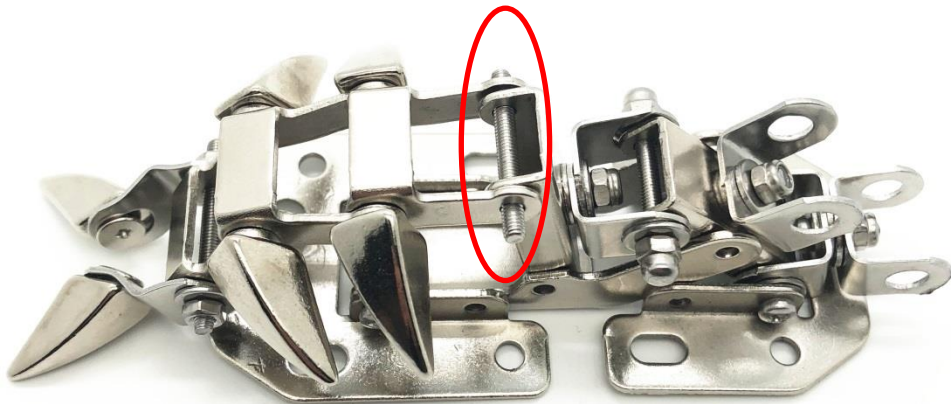

69

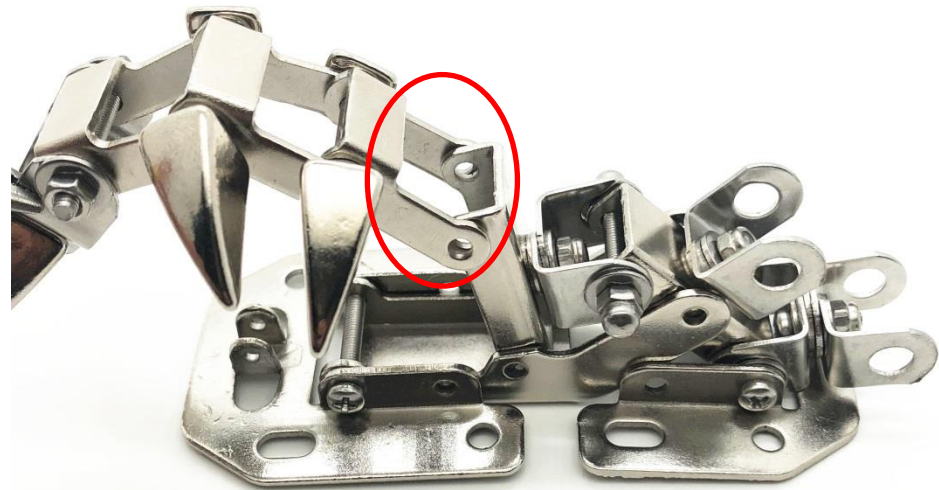

68

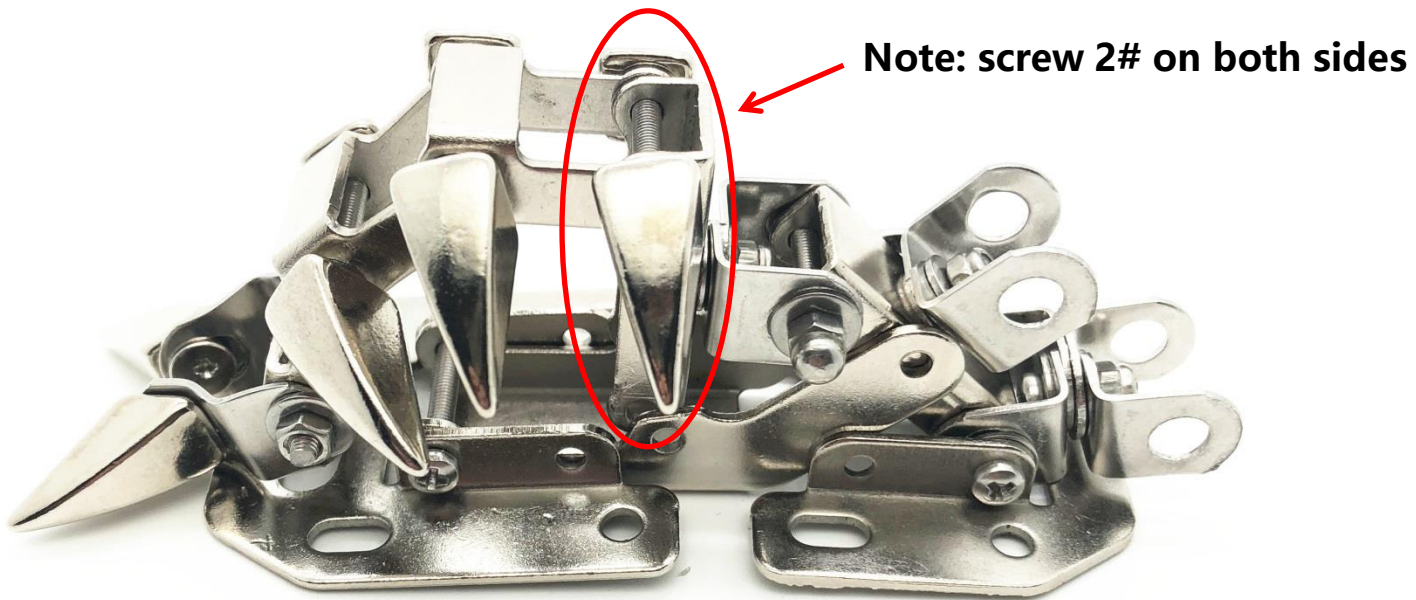

45

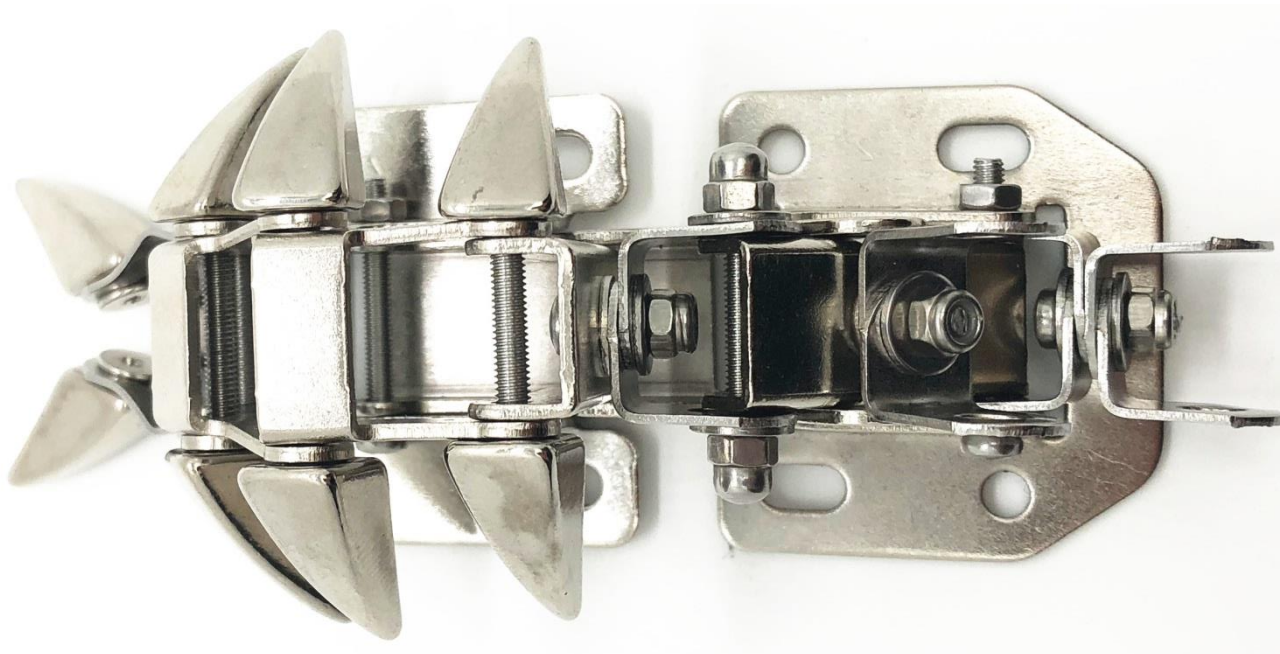

46

**Congratulations! The assembly of body is done**

## **Tail Assembly**



Tail joints x 7

Lock nut

M3×10

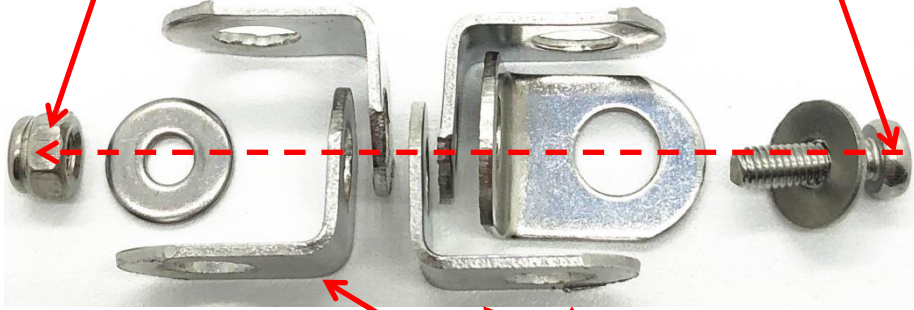

Note: Use holes of 5 numer 8 parts on the short sid

08

72

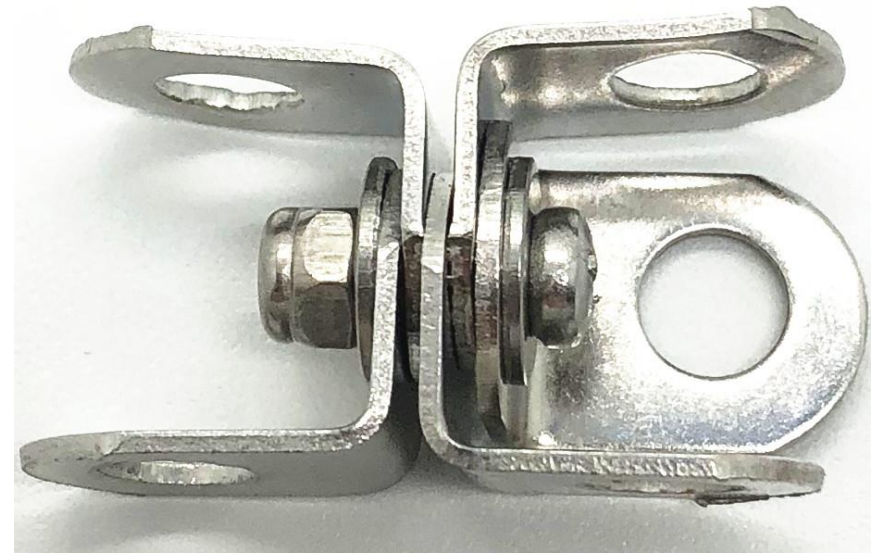

73

Tail joints x 7

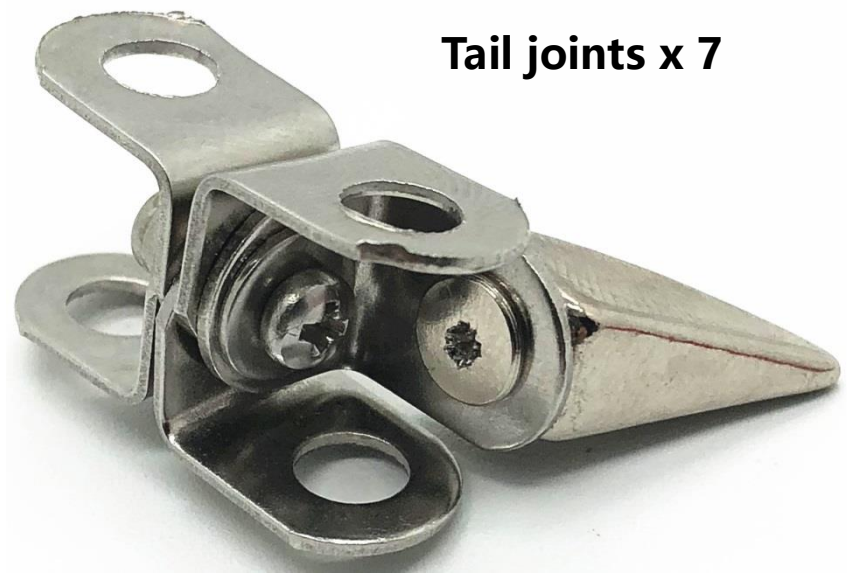

75

02

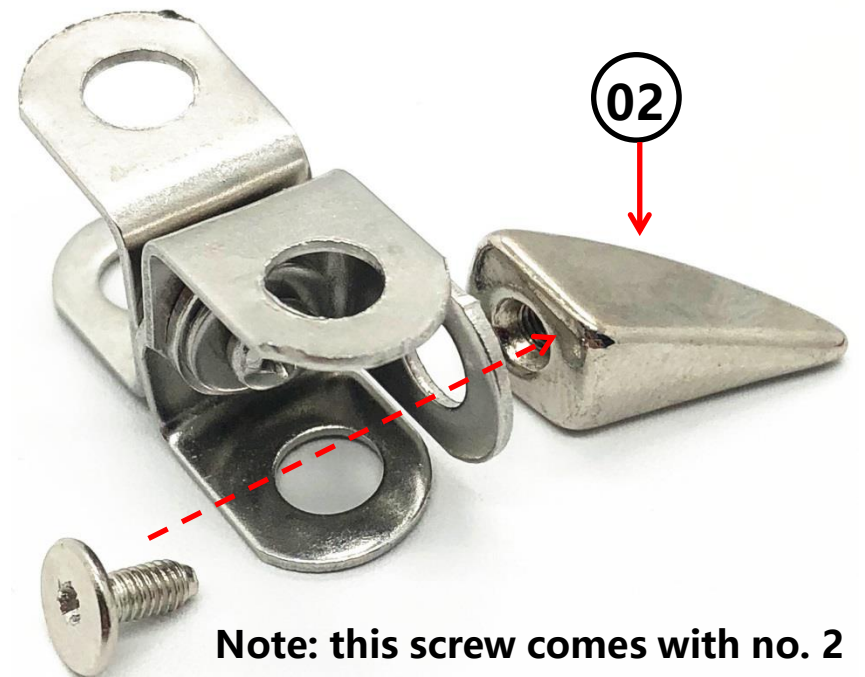

Note: this screw comes with no. 2

74



76

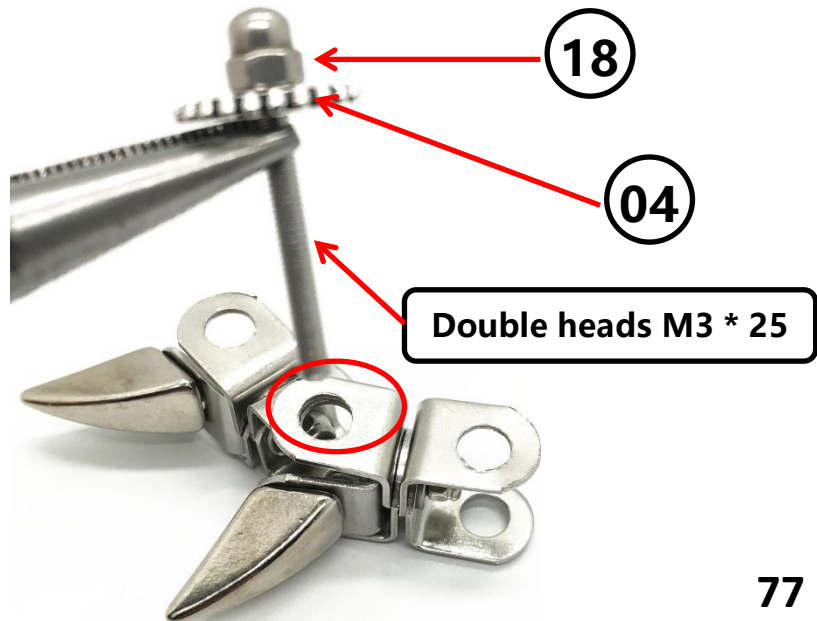

77



79



78



80



81



83



82





86

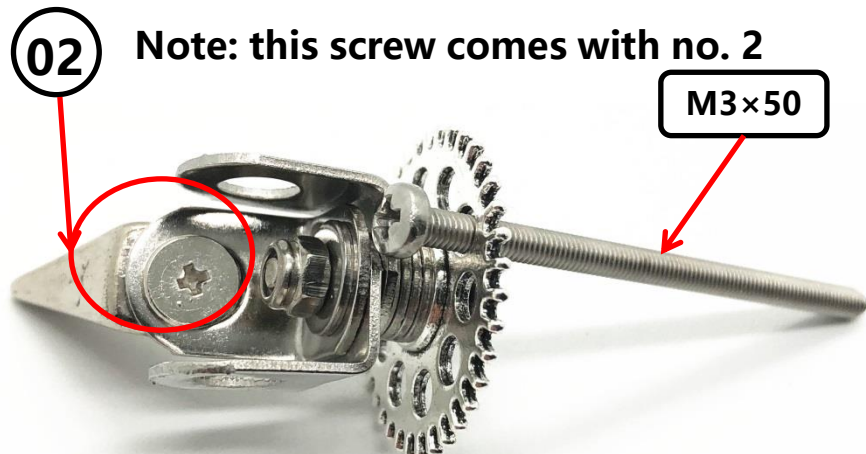

Note: this screw comes with no. 2

M3x50

87

Note: spacing one hole

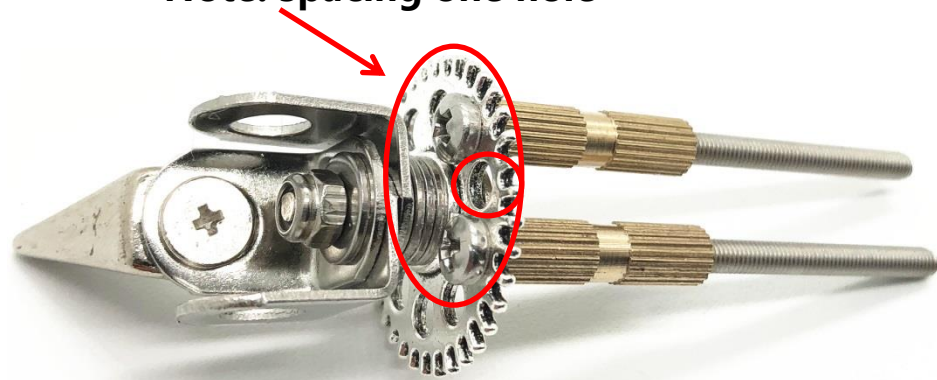

89

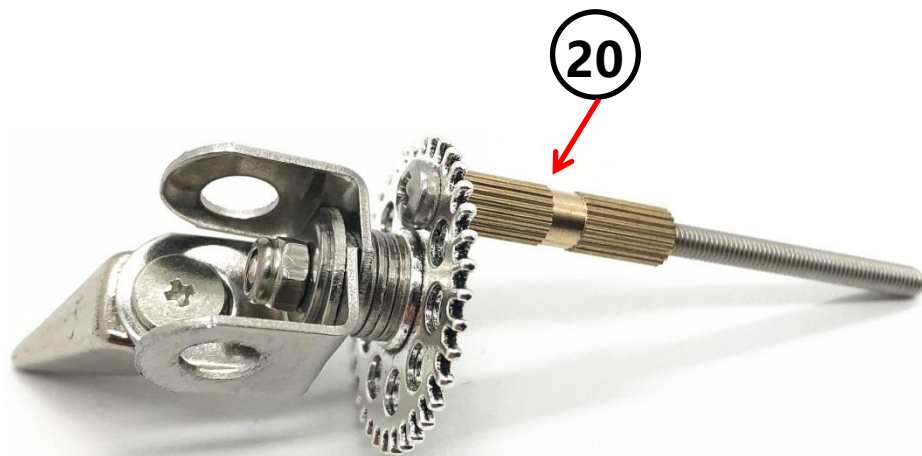

88



90

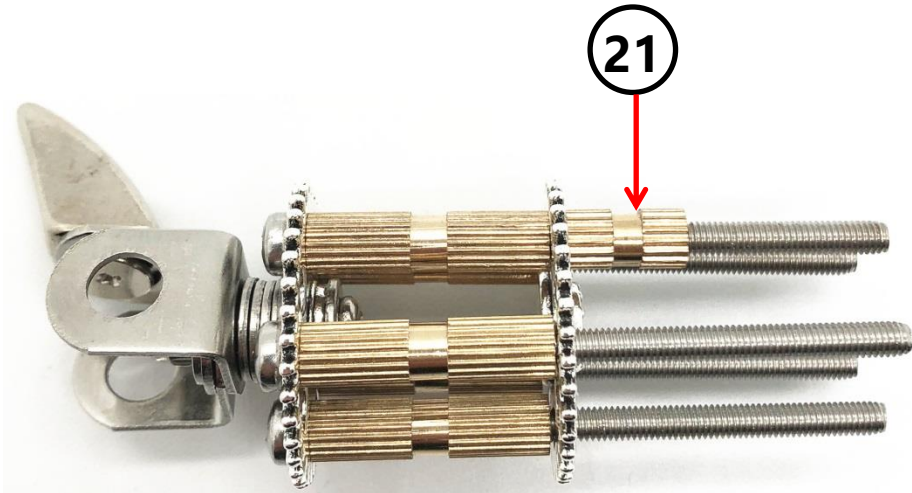

91



93

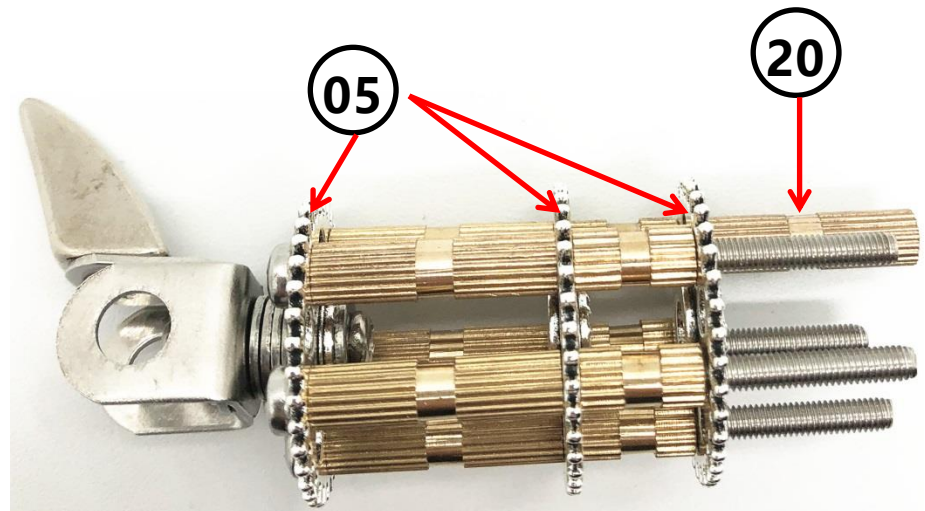

92

02

Double heads M3 \* 25





**Congratulations! The assembly of tail is done**

**The way to assemble back cannon**



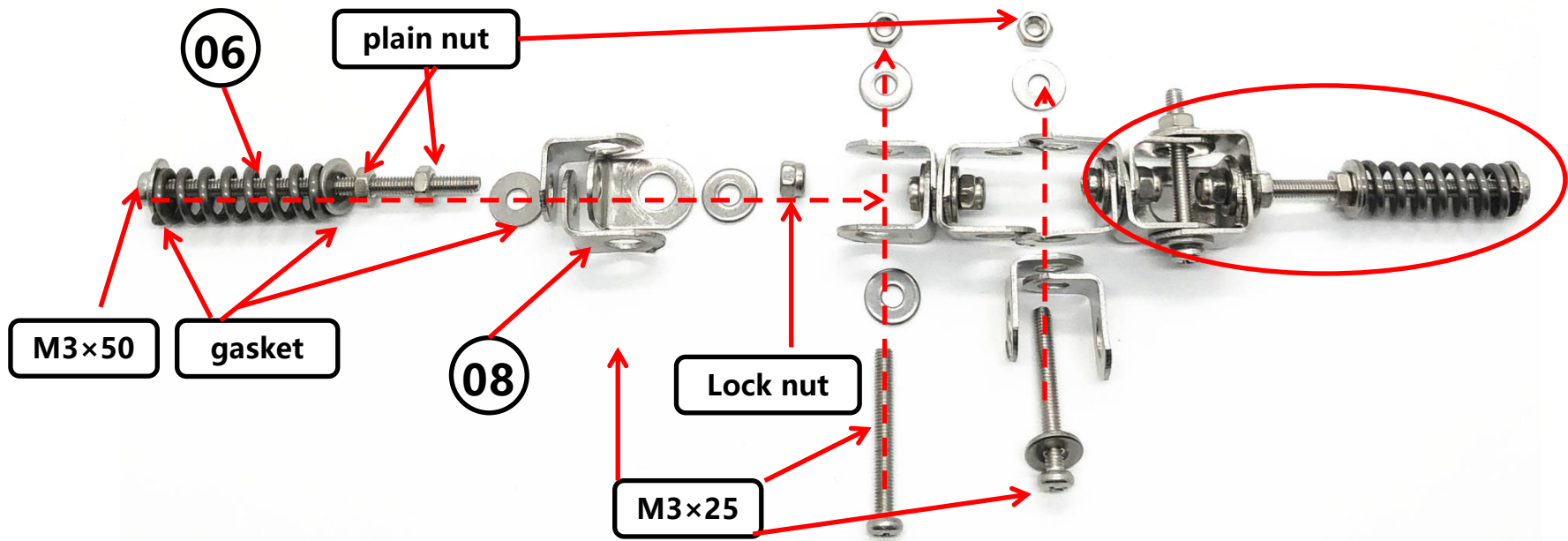

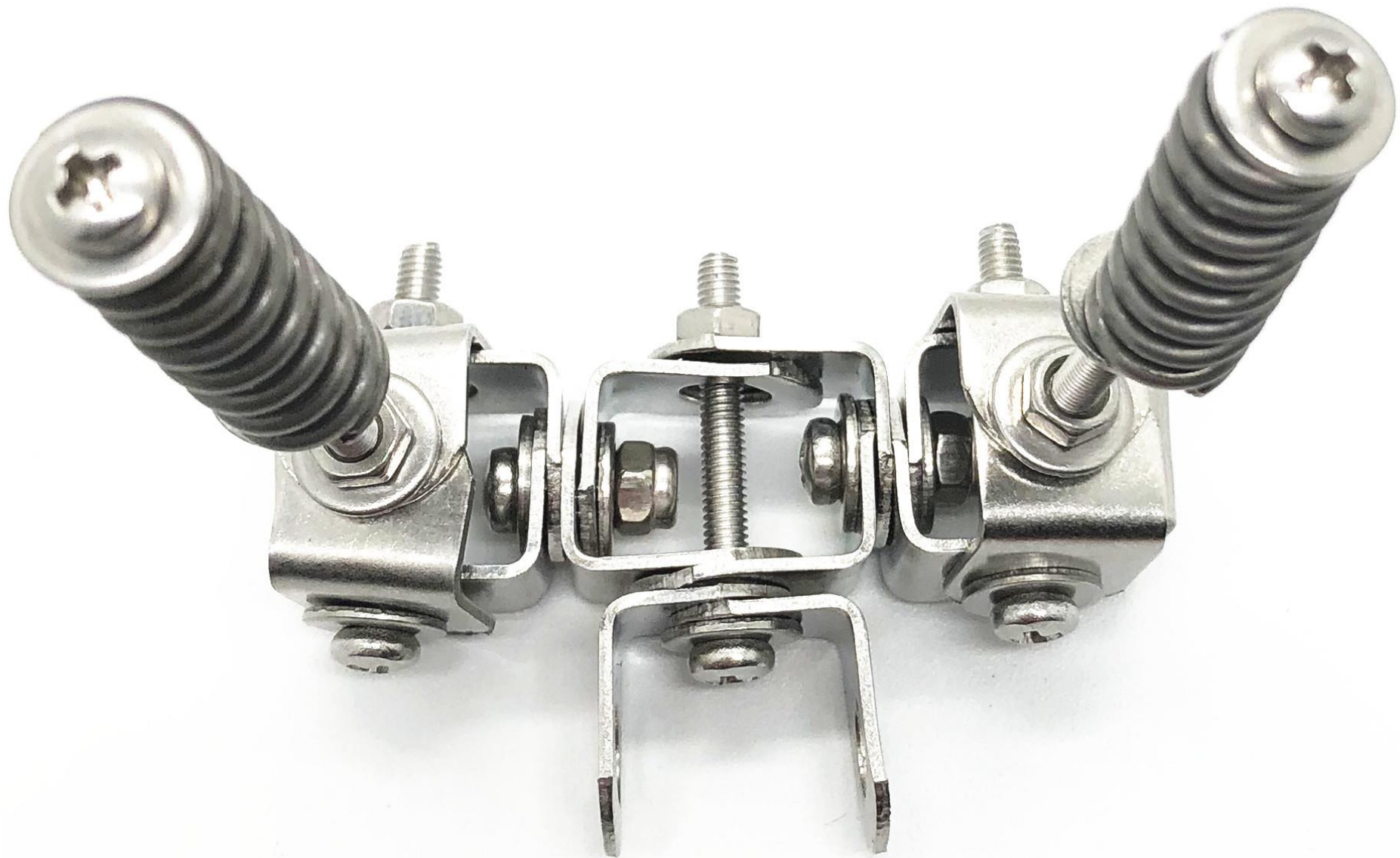

**Congratulations! The assembly of back cannon is done**

**Whole assembly**



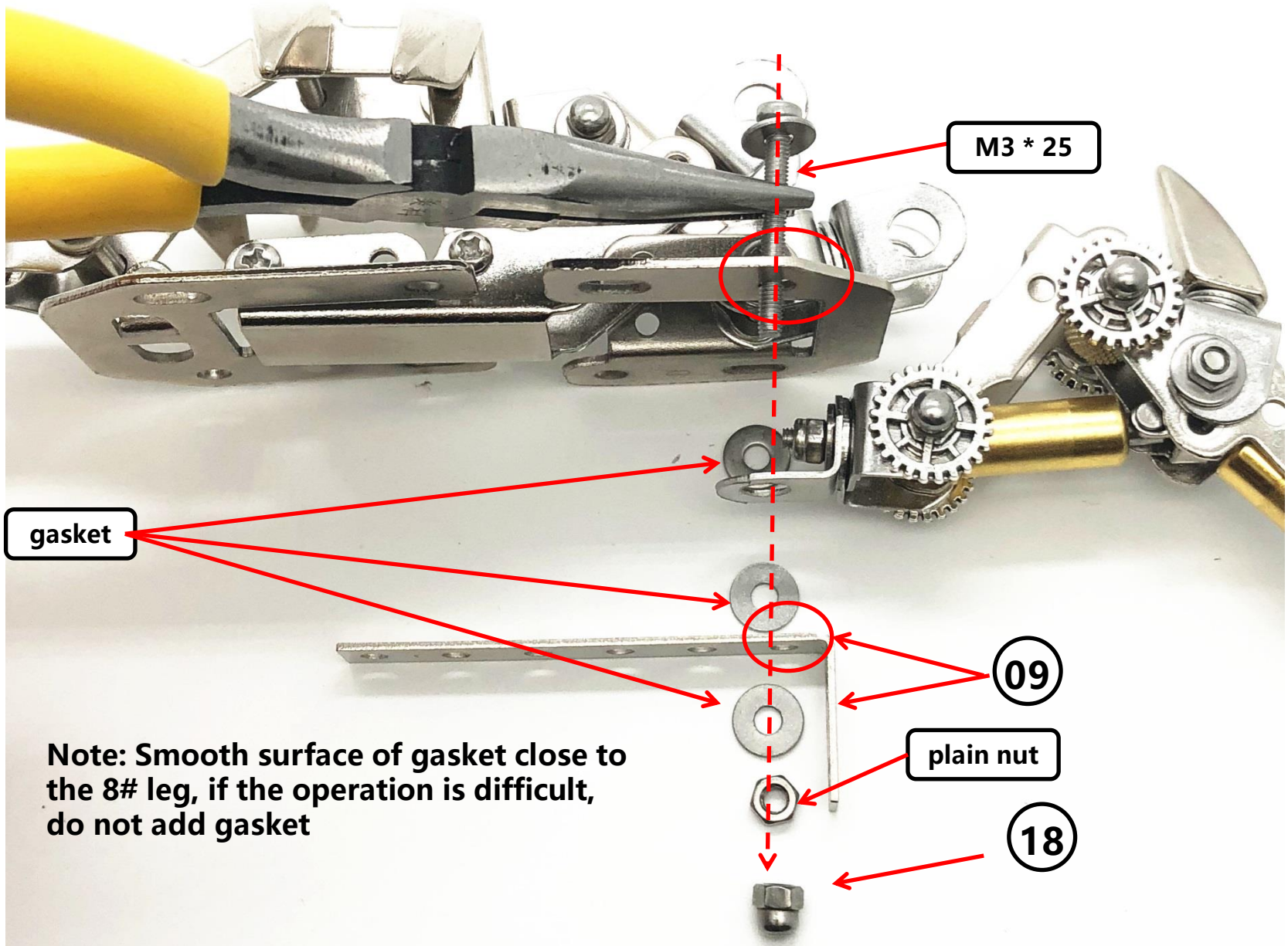

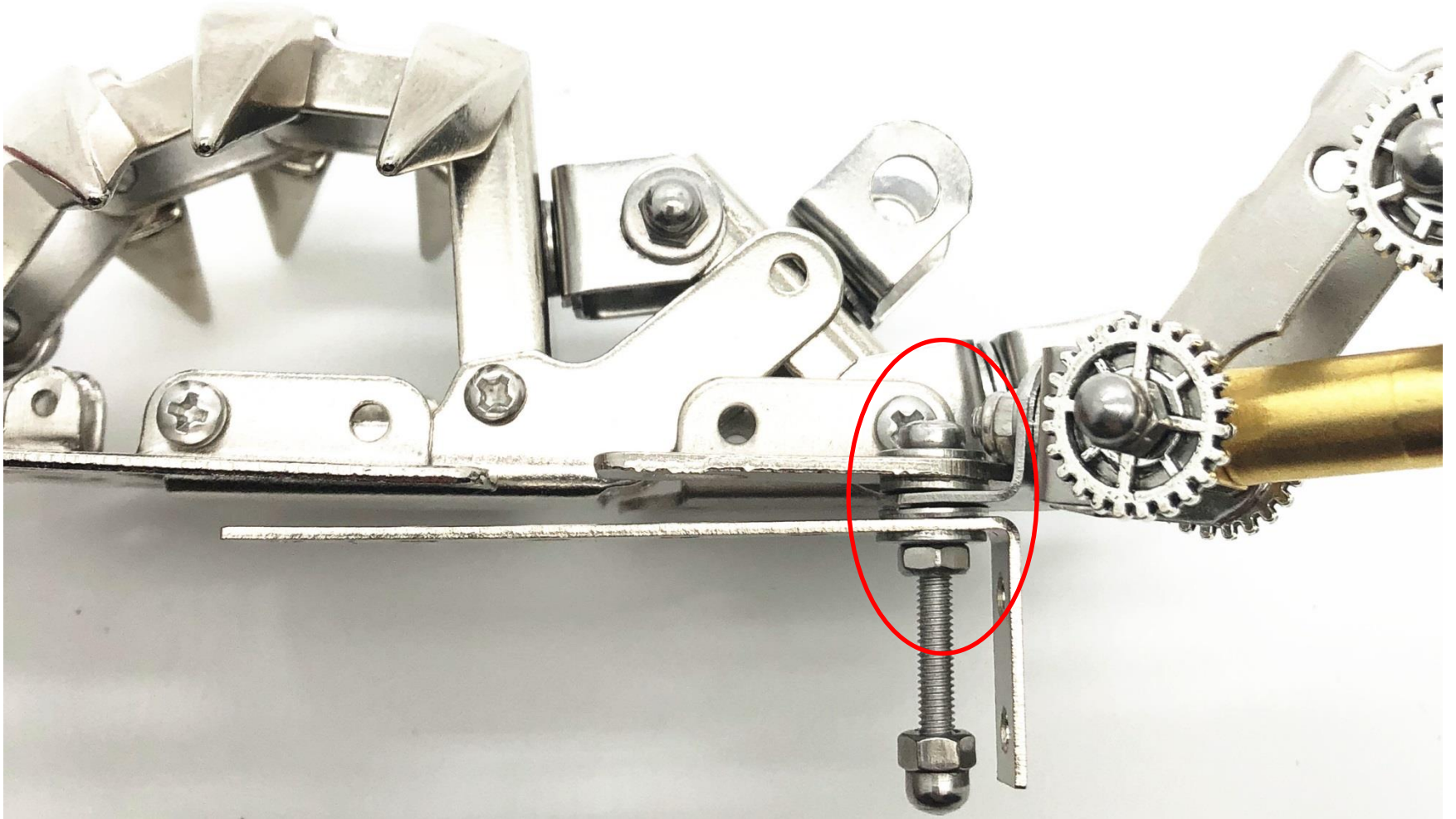

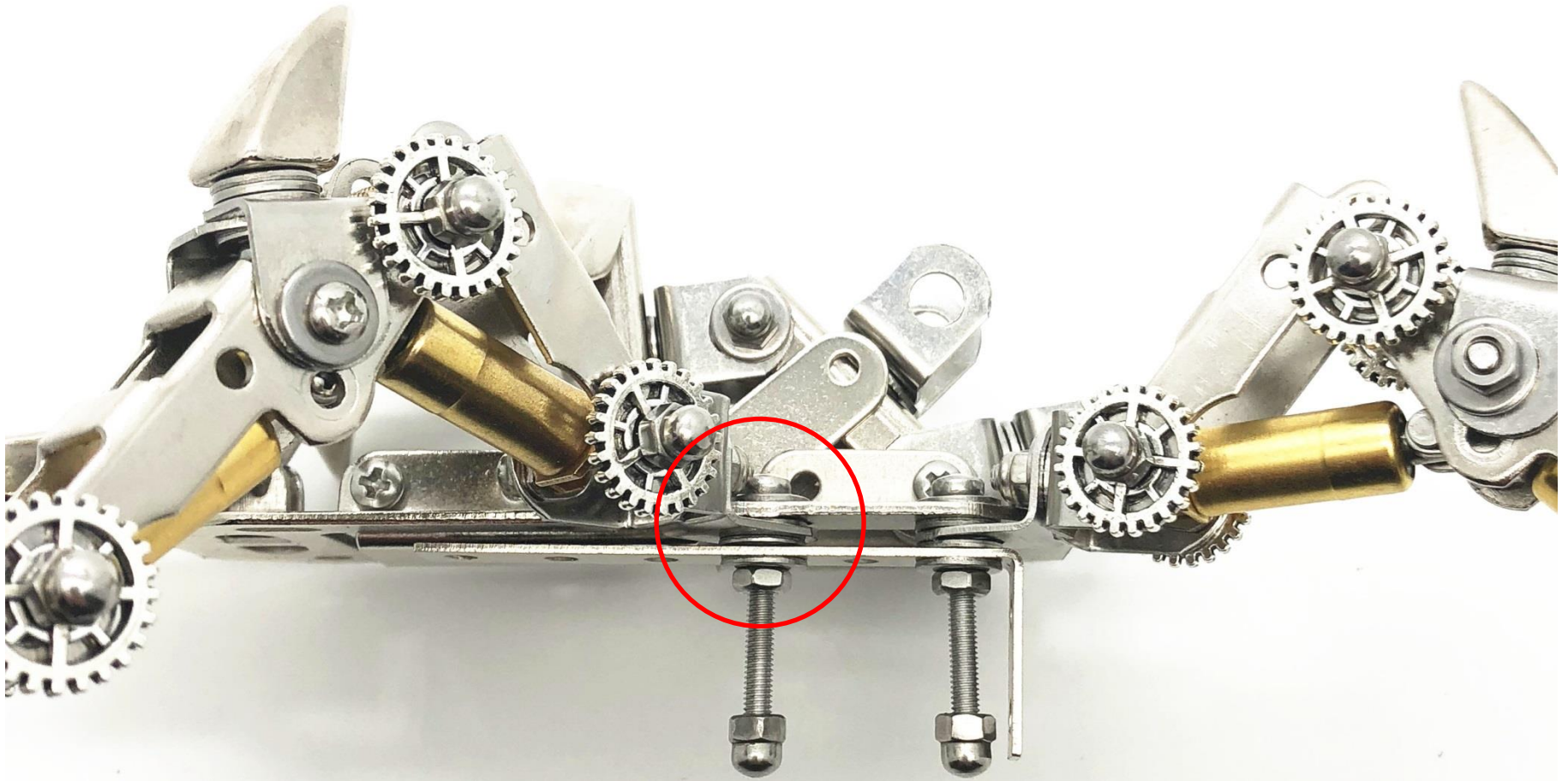

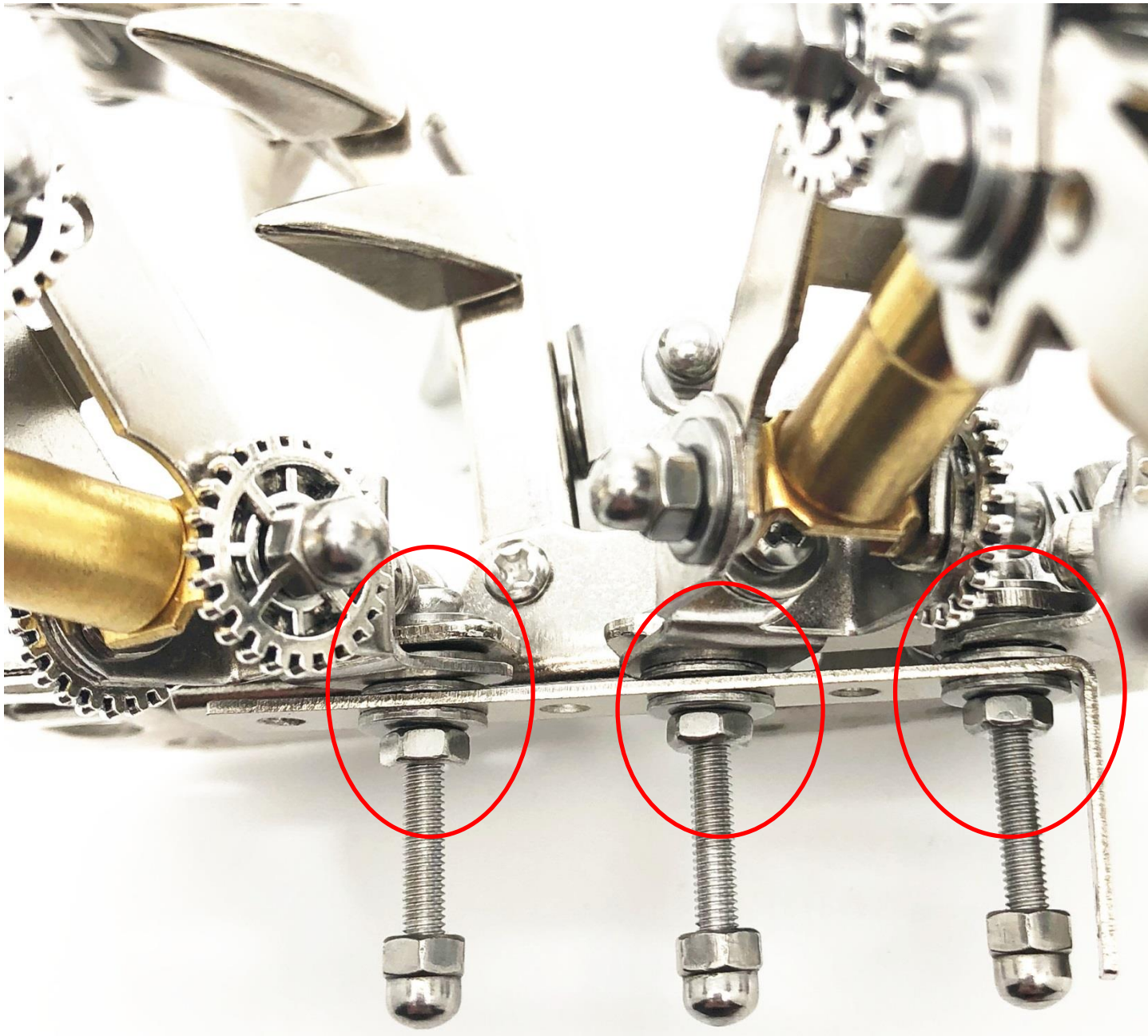

**Note: assembly of the front sea turtle**

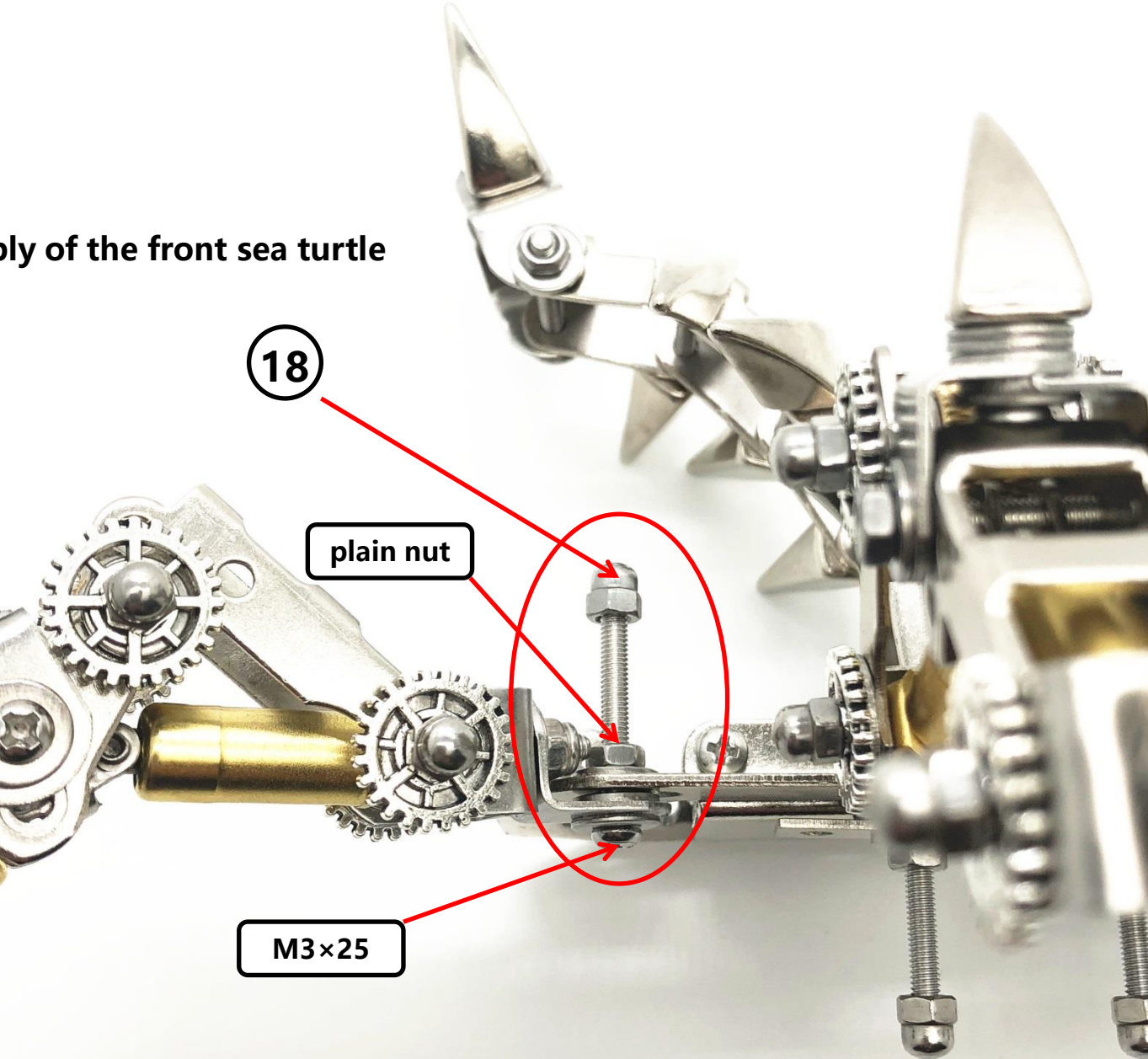





107



108



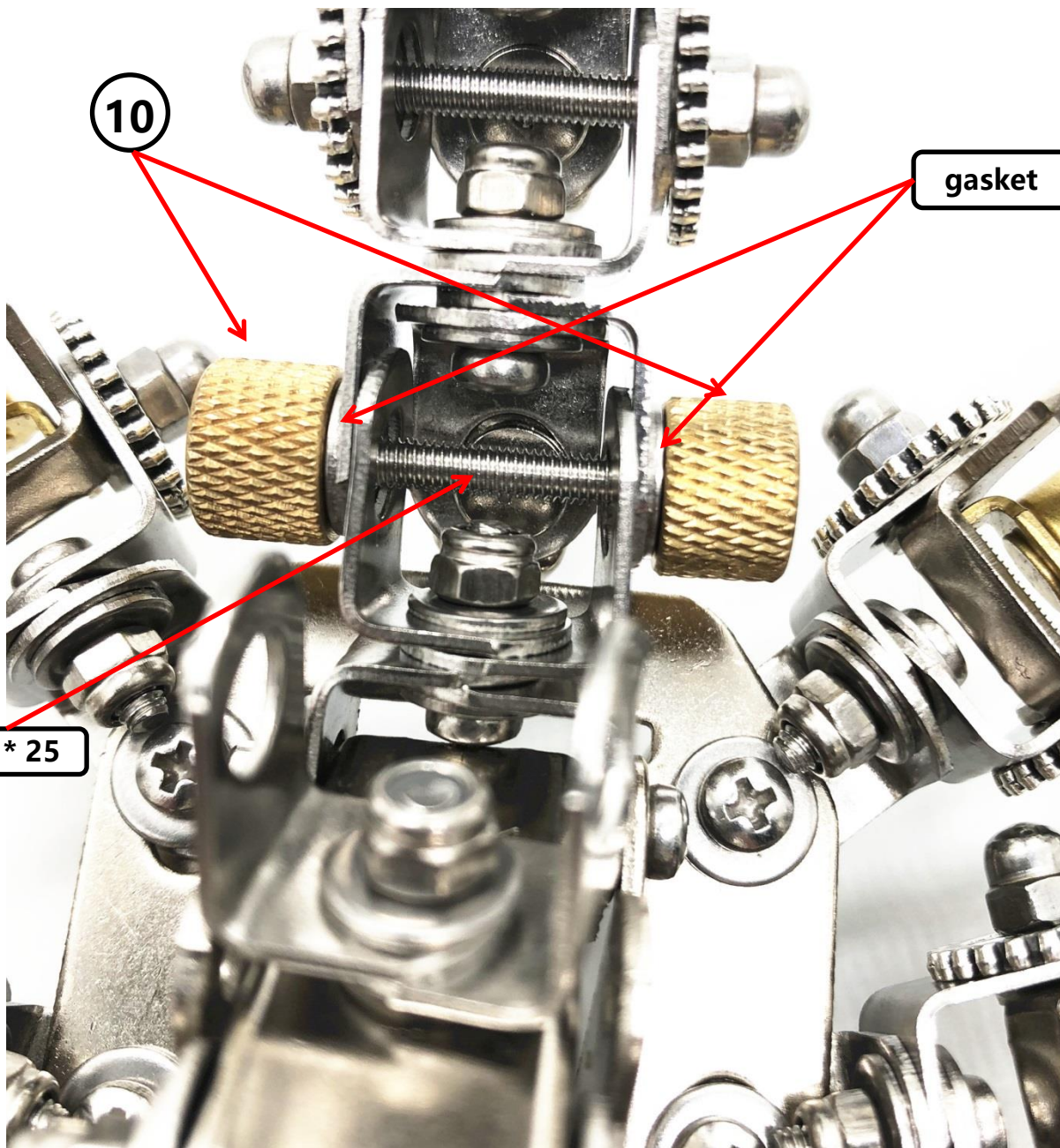

10

gasket

Double heads M3 \* 25



Double heads M3 \* 25

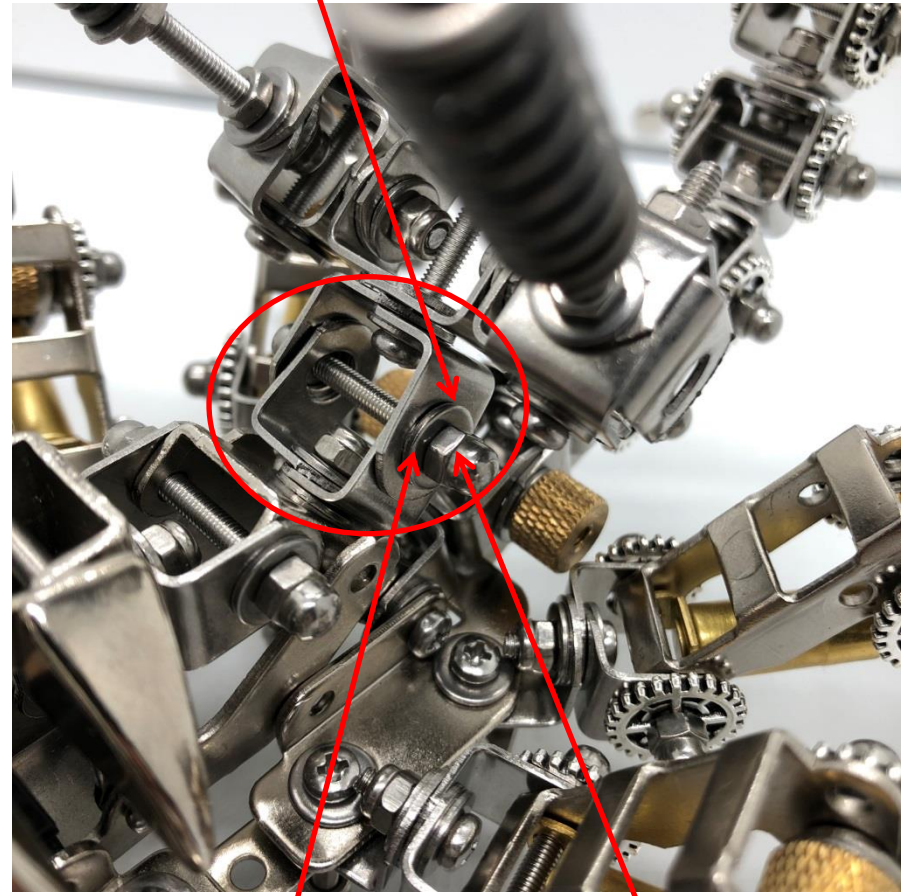

gasket

18

**Congratulations! The assembly of scorpion is done**

